

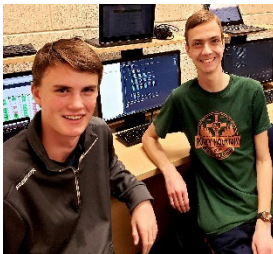

ACADEMY DISTRICT 20

# College and Career Services

Your Path to College and Career



## Program Guide

2026-2027

The purpose of this program guide is to provide middle and high school students and their parents with valuable information on district and site-based college and career services and programs offered throughout Academy School District 20.



## MISSION

We educate and inspire students to thrive.

## VALUES

We believe people are the heart of our success.

We believe relationships matter.

We believe in quality education.

## VISION

We provide creative and personal learning opportunities accessible to all students, preparing them to thrive in an ever-changing world.

---

Development and publication of this program guide was funded in part by grant dollars obtained through the Strengthening Career and Technical Education for the Twenty First Century Act (Carl D. Perkins Act V) and the Colorado State Board for Community Colleges and Occupational Education (SBCCOE) which oversees all Career and Technical Education (CTE) programs for the state of Colorado.

**Disclaimer:** Every effort was made to ensure accuracy in this program guide at the time of publication (January 2025). Due to continued evaluation, refinement, funding, staff availability, and program changes beyond our control, information herein is subject to change. Please contact the school of the specific program of interest for the most current information.



<b>Table of Contents</b>	<b>Page</b>
<b>College and Career Services District and Site Contacts</b>	5
College and Career Services Website	5
College and Career Services Administrative Team	5
High School Site Phone Numbers and College and Career Websites	5
<b>Moving into the Future...What's New!</b>	6
Colorado Senate Bill 25-315 aka "The Big Three"	6
ASD20 College and Career Navigator	8
<b>Individual Career and Academic Plan (ICAP)</b>	8
<b>Career and Technical Education (CTE) Programs</b>	9
Career & Technical Education Brings Relevancy to Education Program	9
CTE Involvement Allows for Participation in Co/Extra-Curricular Programs	9
How to Get Involved in a CTE Program	9
Academy District 20 CTE High School Programs	11
Middle School CTE Programs	12
"Center of Excellence," CTE Programs Open to Students District-Wide	12
Automotive Service Technology Program at Liberty High School	12
Building Construction Technology Program at Liberty High School	12
<b>College Credit Opportunities for Students Involved in CTE Programs</b>	14
Career Start at Pikes Peak State College (PPSC)	14
PPSC Medical Field Programs at Academy District 20	15
Teacher Cadet Program	17
Project Lead the Way (PLTW) in Engineering and Biomedical Science	18
<b>Work-Based Learning (WBL) Opportunities</b>	20
<b>School to Work Alliance Program (SWAP)</b>	24
<b>Concurrent/Dual Enrollment College Credit Opportunities</b>	25
College Credit for Courses Taken During High School	27
Concurrent Enrollment (UCCS, MSU, PPSC)	28
Applying for Concurrent/Dual Enrollment or "Center of Excellence"	27
Districtwide CTE Programs	29
College Opportunities Checklist	30
District 20 General Concurrent/Dual College Enrollment Guidelines	33
High School Credit and Weighting for College Coursework	34
Rampart Early College Academy (at Rampart High School)	35

<b>Table of Contents</b>	<b>Page</b>
CU Succeed at a D20 High School	36
UCCS Pre-Collegiate Development Program	36
Outside College Credit from Non-Sponsored D20 Dual Enrollment	37
University of Colorado (CU Succeed Platinum) Online	38
MathOnline (UCCS)	39
College Credit for International Baccalaureate (IB) Programs	39
College Credit for Advanced Placement (AP) Courses	40
<b>Appendix A—Career Start at Pikes Peak State College: Credit Allocation</b>	42
<b>Appendix B—Pikes Peak State College Courses that are Guaranteed to Transfer and Approved for Weighted Concurrent Enrollment Credit</b>	48
<b>Appendix C—University of Colorado Colorado Springs Courses that are Guaranteed to Transfer and Approved for Weighted Outside Agency Credit</b>	50
<b>Appendix D—Courses Currently Authorized for PLTW or CU Succeed Credit at D20 High Schools</b>	52
<b>Appendix E—Metropolitan State University of Denver Courses that are Guaranteed to Transfer and Approved for Weighted Outside Agency Credit</b>	58

In compliance with Titles VI and VII of the Civil Rights Act of 1964, Title IX of the Education Amendments of 1972, Section 504 of the Rehabilitation Act of 1973, the Age Discrimination in Employment Act of 1967, the Americans with Disabilities Act, the Genetic Information Nondiscrimination Act of 2008, Colorado law and district administrative policy AC (Nondiscrimination/Equal Opportunity), Academy District 20 does not discriminate on the basis of disability, race, creed, color, sex, sexual orientation, marital status, national origin, religion, ancestry, age, genetic information, or conditions related to pregnancy or childbirth in admissions, access to, treatment, or employment in educational programs or activities which it operates.



## College and Career Services (CCS) District and Site Contacts

Website: <https://www.asd20.org/college-and-career/>

### Academy District 20 College and Career Services Administration Team

---

Susie King, CCS Executive Secretary/Registrar	719-234-1344	<a href="mailto:susanna.king@asd20.org">susanna.king@asd20.org</a>
Kendra Tate, Director for CCS	719-234-1342	<a href="mailto:kendra.tate@asd20.org">kendra.tate@asd20.org</a>
Calla Guillory, CCS Coordinator, Dual/Concurrent Enrollment	719-234-1333	<a href="mailto:calla.wooldridge@asd20.org">calla.wooldridge@asd20.org</a>
Breann Shaughnessy, CCS Coordinator, Career Technical Education	719-234-1668	<a href="mailto:breann.shaughnessy@asd20.org">breann.shaughnessy@asd20.org</a>
Tala Harmon, Work-Based Learning Coordinator	719-234-1306	<a href="mailto:tala.harmon@asd20.org">tala.harmon@asd20.org</a>
Michelle Casner, SWAP Coordinator	719-234-1377	<a href="mailto:michelle.casner@asd20.org">michelle.casner@asd20.org</a>
Morgan Markewich, SWAP Coordinator	719-234-1369	<a href="mailto:morgan.markewich@asd20.org">morgan.markewich@asd20.org</a>

---

### High School Site Phone Numbers and College and Career Websites

---

<b>Air Academy High School</b> 719.234.2400	<a href="http://airacademy.asd20.org/college-and-career/">http://airacademy.asd20.org/college-and-career/</a>
<b>Aspen Valley High School</b> 719.234.6200	<a href="https://aspensvalleyhigh.asd20.org/college-and-career/">https://aspensvalleyhigh.asd20.org/college-and-career/</a>
<b>Discovery Canyon High School</b> 719.234.2800	<a href="https://dcchigh.asd20.org/college-and-career/">https://dcchigh.asd20.org/college-and-career/</a>
<b>Liberty High School</b> 719.234.2200	<a href="https://liberty.asd20.org/college-and-career/">https://liberty.asd20.org/college-and-career/</a>
<b>Pine Creek High School</b> 719.234.2600	<a href="https://pinecreek.asd20.org/counseling/college-and-career/">https://pinecreek.asd20.org/counseling/college-and-career/</a>
<b>Rampart High School</b> 719.234.2000	<a href="https://rampart.asd20.org/college-and-career/">https://rampart.asd20.org/college-and-career/</a>
<b>Village High School</b> 719.234.1970	<a href="https://village.asd20.org/college-and-career/">https://village.asd20.org/college-and-career/</a>

---

## Colorado Senate Bill 25-315 aka “The Big Three”

Senate Bill 25-315 establishes statewide postsecondary readiness standards, commonly referred to as “The Big Three.” This legislation emphasizes ensuring that students graduate high school with meaningful, transferable outcomes that support successful transitions into postsecondary education, training, or the workforce.

The statewide goal established by SB 25-315 is for 100% of graduating seniors in the Class of 2029, and every graduating class thereafter, to earn at least one of The Big Three prior to graduation. This goal reinforces the importance of intentional career planning, equitable access to postsecondary opportunities, and strong alignment between education and workforce readiness.

### What are “The Big Three”?

Under SB 25-315, students may demonstrate postsecondary readiness by earning *at least* one of the following prior to graduation:

- 12 College Credits  
Students earn a minimum of 12 postsecondary credits through approved opportunities such as concurrent enrollment, dual enrollment, Advanced Placement (AP) or International Baccalaureate (IB) coursework, or other qualifying college coursework.
- An Industry-Recognized Credential  
Students earn a credential that is recognized by industry and aligned to workforce needs, validating technical skill attainment and employability within a specific career field. Not every earnable credential will qualify, it must be a credential that is included on the List of Qualifying Credentials (aka IRC List, formerly known as CDIP).
- A High-Quality Work-Based Learning Experience  
Students complete a sustained, high-quality work-based learning experience that aligns with their Individual Career and Academic Plan (ICAP). These experiences emphasize real-world application of academic, technical, and employability skills and meet state and district quality expectations. The activity types that qualify are things such as internships, pre-apprenticeships, supervised entrepreneurship experiences, and industry sponsored projects.

For information on how D20 is addressing the Industry Recognized Credentials and College Credit portions of The Big Three, please see the College and Career Services Program Guide.

### Big Three Resources:

- Read [Senate Bill 25-315 “The Big Three”](#)
- Fiscal Note: [SB 25-315: POSTSECONDARY & WORKFORCE READINESS PROGRAMS](#)
- [SB25-315 Postsecondary & Workforce Readiness Programs | Colorado General Assembly](#)
- [SB25-315 Implementation - Colorado Department of Education](#)
- Data Collection/Tracking: [Postsecondary and Workforce Readiness Collection - Colorado Department of Education](#)
- Data Collection
  - [2025-2026 WBL File Layout](#) (format for Data Collection; tables from the file layout have been included on the next page and links are available below.)
    - ♣ [WBL Upload Template](#)

♣ [2025-26 WBL Industry Type Codes](#)

- PWR Data Collection will open April 13th, 2026 and close June 30, 2026 for the 2025-26 school year.

## ASD20 College and Career Navigator

ASD20 students have access to a comprehensive college and career readiness solution, the ASD20 College and Career Navigator (aka D20 Navigator). The D20 Navigator utilizes a Career-Centric Pathway Planning model, which puts the career as the destination for all students, allowing them to build a pathway around their specific cluster, career, or occupational aspirations.

The model assists students in defining their aspirations through an evaluation of their interests, skills, and values, then helps them to build an education and training plan that encompasses high school courses, experiential learning, and continuing education to pave the path toward their best-fit career.

The D20 Navigator is a tool we can use to reimagine the Individual Career and Academy Plan (ICAP) process through early and focused career awareness curriculum that supports students identifying career interests and aligning those with educational pathways in D20, as well as providing guidance about what students' paths might look like after high school.

## Individual Career and Academic Plan (ICAP)



Colorado Legislation requires that all districts assist high school students in creating an Individual Career and Academic Plan (ICAP). Not only a legal requirement, the ICAP is good educational practice; therefore, D20 goes beyond the 9-12 grade requirement by starting this process in 6<sup>th</sup> grade. ICAP helps students explore career and academic opportunities and aids in establishing a plan for students' secondary coursework which aligns to their post-secondary college and career goals. Students develop awareness, knowledge, attitudes, and skills to be college and career ready. In addition to annual goals and course planning, the Academy District 20 ICAP program includes various exploratory and planning activities and is customizable at the school, counselor, and student

levels to best meet the needs of students. Students interact with the D20 College and Career Navigator to engage in ICAP.

Students access the D20 College and Career Navigator through [Clever](http://clever.com/in/asd20) (<http://clever.com/in/asd20>).

Colorado Department of Education ICAP Information Webpage:

<http://www.cde.state.co.us/postsecondary/icap>

Meaningful Career Conversations:

<https://www.cde.state.co.us/postsecondary/pwrplaybookmeaningfulcareerconversations>

Career Guidance Best Practices:

<http://coloradostateplan.com/career-guidance/career-guidance-best-practices/>

Academy District 20 Policy IHBK: Preparation for Postsecondary and Workforce Success

<http://go.boarddocs.com/co/asd20/Board.nsf/goto?open&id=C42P9H5BCB07>



## Career & Technical Education (CTE) Programs

A CTE program is a sequence of two or more career/industry-specific themed courses within one of six career clusters and seventeen industry sectors. The CTE program courses are built upon one another and must be taken in sequence. “Shop class” or “vocational education” of the past may come to mind when thinking of CTE programs, but this is not an accurate view of modern CTE programs. CTE programs are standards-aligned courses that focus on learning and applying rigorous and relevant academic skills, employability skills, and technical skills. If your goal is to pursue an interest in automotive technology, engineering, medical fields, technology, business, etc., there is a pathway for you.

Through CTE programs, students acquire the skills necessary for entry into well-paid careers and/or post-secondary college/university programs. CTE pathways also provide purpose to their high school program and to their post-high school professional lives, thereby providing a higher degree of personal satisfaction and encouraging greater levels of responsibility.

Many CTE programs also provide work-based learning (WBL) opportunities (guest speakers, industry tours, job shadows, and internships) in addition to industry-based certification opportunities or even college credit. In addition, CTE programs provide opportunities for leadership development and competitions through participation in student organizations aligned to the CTE pathway industry sector.

### CTE Involvement Allows for Participation in Co/Extra-Curricular Programs

Students can be involved in multiple academic, co-curricular, or extracurricular programs and still be in a CTE program. Students are encouraged to work with their counselors to choose courses that support their CTE interests and future plans, whether that includes college, a career, or both.

# How to Get Involved in a CTE Program

Each of the Academy District 20 high schools offers specific CTE programs unique to each high school in addition to several programs that are open to all district students no matter which high school they attend. Upon registering for courses, students should utilize this program planning guide and discuss the different CTE pathways options and alignment with the students' ICAP goals with their school counselor.

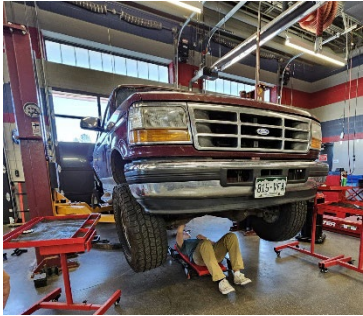

# Academy District 20 Career Technical Education (CTE) High School Programs



Air Academy HS	Aspen Valley HS	Discovery Canyon HS	Liberty HS	Pine Creek HS	Rampart HS	The Village HS
Aviation		Biomedical Science©	<b>Automotive Tech**</b>	Biomedical Science©	American Sign Language (ASL)- Education ©	Business & Marketing
Business & Marketing		Business & Marketing©	<b>Construction Tech.**</b>	Business & Marketing	Business & Marketing©	Education (Teacher Cadet)
Digital Media	Multimedia	<b>Education (Teacher Cadet)**©</b>	Business & Marketing	Computer Science & Cyber Security©	Computer Science and Cyber Security	
Engineering©		Engineering©	<b>Certified Nurse Assistant (CNA)**©</b>	Digital Media	Digital Media©	
			<b>Emergency Medical Tech. (EMT)**©</b>	Graphic Arts	Family and Education Science	
			Digital Media			
			Wood Production			

\*\*Open to students at all high schools, **Centers of Excellence**

© College Credit opportunity through PLTW/UCCS, Teacher Cadet/UCCS, IB, AP, PPSC, or UCCS.

## Middle School CTE Programs

Academy District 20 offers 16 CTE programs in six of our middle schools. Middle School CTE programs are exploratory in nature, focused on exploring connections to career possibilities through exposure to various industry sectors. CTE introduces students to their interests, resulting in relevant learning with an increase in their engagement, which better informs their ICAP planning for high school and post-secondary. Middle School programs are open to students who are attending those schools. Below is a table of ASD20 middle school CTE exploratory programs:



Challenger	Chinook Trail	Discovery Canyon	Eagleview	Mountain Ridge	Timberview
Digital Media	Digital Media	-	Digital Media	Digital Media	Digital Media
-	-	Industrial Technology	Industrial Technology	Industrial Technology	Industrial Technology
-	-	STEM-Engineering	STEM-Computer Technology	-	-
-	-	-	Theater Production	Theater Production	Theater Production

## Center of Excellence, CTE Programs Open to Students District-Wide

CTE programs are generally site-specific to the high school which a student attends, but there are several district CTE programs “Center of Excellence,” that are available to all district school students regardless of their D20 high school of attendance (see page 27 for age/grade limitations for each program). If more qualified applicants exist than there is space, a lottery system will be utilized. Approved students will be provided with release time to attend the CTE program at the high school where the program is housed. Students may be responsible for securing their own transportation to and from their chosen program. The table below lists the district CTE programs.

District CTE Programs	Program Location
Automotive Service Technology	Liberty High School
Building Construction Technology	Liberty High School
Certified Nurse Assistant (CNA)*	Liberty High School (PPSC program)
Emergency Medical Technician (EMT)*	Liberty High School (PPSC program)
Teacher Cadet*	Discovery Canyon High School

\*The **Teacher Cadet**, **CNA**, and **EMT** programs are explained in more detail in *College Credit*

### **Automotive Service Technology Program at Liberty High School**

In this two-year course sequence, students participate in real-world auto service training through maintenance, diagnosis, removal, and installation of specific automotive drivetrain components. Students focus on industry standard processes and safety procedures in the environment of a working auto shop. Students learn through competency-based instruction that leads to industry standard Automotive Service Excellence (ASE) certification. Students will gain a foundation for entry-level employment or further schooling/training.

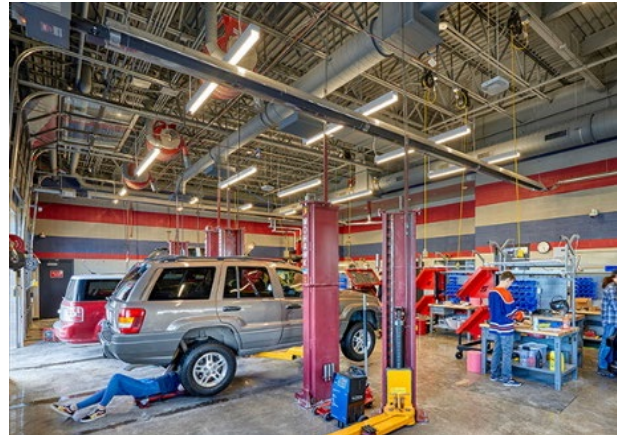

### **Building Construction Technology Program at Liberty High School**

In this two-year program, students will apply technical knowledge and skills to residential and commercial building construction and remodeling through authentic construction projects. This course introduces students to all aspects of construction with a focus on Home Builder's Institute (HBI) Pre-Apprentice Certification Training (PACT) in the following areas: (1) Building Trades, Safety, and First Aid; (2) Construction Math; (3) Tools & Construction Materials; and (4) Employability. Students will gain a foundation for entry-level employment or further schooling/training.



## College Credit Opportunities for Students Involved in CTE Programs

Several high school CTE programs allow for college credit based on the specific curriculum being taught in the high school course itself (i.e., Project Lead the Way) or based on articulation agreements with a college, or college courses offered on D20 campuses. For the most current list of articulated CTE courses at Pikes Peak State College (PPSC), please visit their High School Articulation website:

<https://www.pikespeak.edu/academics/high-school-programs/hsp-resources/articulation.php>

High School	PPSC Articulated Courses
Discovery Canyon HS	Introduction to Engineering Design—EGG1020 Engineering Methods (3 credits) It's Your Business—BUS 1015 Introduction to Business (3 credits)
Liberty HS	Photography 1—PHO 1020 Fundamentals of Photography (3 credits) Accounting Principles—ACC 1001 Fundamentals of Accounting (3 credits)
Pine Creek HS	It's Your Business—BUS 1015 Introduction to Business (3 credits)
Rampart HS	It's Your Business—BUS 1015 Introduction to Business (3 credits) Electronic Media 1 & 2—RTV 1002 Beginning Television (3 credits) Electronic Media 3 & 4—RTV 1005 Basic Video Production (3 credits)

In addition, D20 has a partnership with PPSC which allows students to get release time to take CTE programs at the college-level on PPSC's campus (Career Start program, see next page). For non-CTE based college credit opportunities, please visit the *Concurrent/Dual Enrollment College Credit Opportunities* section of this program guide (page 25).



### CAREER START at Pikes Peak State College (PPSC)

High school juniors and seniors can apply for this half-day program in a technical or trade area of study. Students earn core elective high school credit as well as college credit that can be applied to an associate degree program or obtain an industry certification. Students attend courses at PPSC Centennial Campus. Here is a list of the D20 sponsored programs being offered in Career Start:

PPSC Career Start Programs	
Automobile Collision Technology	Fire Science Technology
Early Childhood Education	Health Science Technology
Broadcast & Electronic Media	Health Career Exploration
Criminal Justice	Multimedia Graphic Design
Culinary Arts	Veterinary Assistant
Cyber Security	Welding
Diesel Power Technology	Zoo Keeping

Please see **Appendix A Career Start at Pikes Peak State College: Credit Allocation** on **page 44** for a breakdown of Career Start programs and courses along with the credit that can be earned at both the high school and college levels.

Students must meet with their high school counselor before completing the District 20 application process electronically. It is recommended that students attend an information session at their school or through District 20 College and Career Services Department. There are also information sessions and Visit Days hosted by PPSC. Program application/registration at PPSC happens in March of each year.

PPSC Career Start Information Page: <https://www.pikespeak.edu/academics/high-school-programs/career-start.php>

District 20 sponsors a total of 60 Career Start students each year; qualified second year students are given priority. Depending on interest and numbers of applications, the D20 application process for first year Career Start may be quite competitive, and all applicants must meet academic qualifications for concurrent enrollment to be considered (See page 32).

Transportation is available for up to 50 Career Start students. The application for transportation is part of the D20 application process for Career Start.

## **Pikes Peak State College Medical Field Programs at Academy District 20**

Academy District 20 is pleased to provide tuition-free PPSC CTE pathway courses at the Liberty High School campus to a limited number of students throughout the district wishing to pursue licensure as a:

- Certified Nursing Assistant (CNA)—80 slots available for 11<sup>th</sup> and 12<sup>th</sup> grade students. There are 40 slots available each semester, as this is a one-semester program.
- Emergency Medical Technician (EMT)—40 slots available for 12<sup>th</sup> grade students. This is a two-semester program.

**College Credit:** Through concurrent enrollment, students accelerate their learning and participate in college courses while still in high school by taking Pikes Peak State College courses that can lead to industry certification. Families save money on college costs, and students earn college credits that may apply toward their future career and educational goals. Qualified students from any high school in D20 may apply for the CNA or EMT program.

### **Certified Nurse Assistant (CNA) at Liberty High School**

In this Pikes Peak State College program (housed at LHS), students prepare for the nurse aide certification exam by expanding foundational healthcare skills and applying basic nursing theory to the practice of client care. Through lab-based simulations and clinical experiences, students will demonstrate nursing principles and competencies, restorative services, safety practices, and emergency care while they model professional skills.

Courses offered in the program may be adjusted by PPSC, but typically include:

PPSC Course	Credit Hours at PPSC	High School Credit in D20
HPR1011: CPR for Professionals	0.5	1 unweighted core elective
NUA1001: Nurse Aide Health Care Skills	4	2 unweighted core electives
NUA1070: Nurse Aid Clinical Experience	1	1 unweighted core elective
NUA1071: Clinical: Advanced Nurse Aid	1	1 unweighted core elective

### Emergency Medical Technician (EMT) at Liberty High School

In this Pikes Peak State College program housed at LHS, students prepare for the National Registry of Emergency Medical Technicians exam by applying foundational healthcare skills to the practice of basic emergency pre-hospital client care. Through classroom simulations and clinical experiences, students will demonstrate an understanding of basic anatomy and psychology, patient assessment, communication strategies, and emergency medical interventions. **PLEASE NOTE:** This program is for seniors only.



Courses offered in the program may be adjusted by PPSC, but typically include:

PPSC Course	Credit Hours at PPSC	High School Credit in D20
EMS1021: EMT Fundamentals	3	2 unweighted core electives
EMS1022: EMT Medical Emergencies	4	2 unweighted core electives
EMS1023: EMT Trauma Emergencies	2	1 unweighted core elective
EMS1024: EMT Special Considerations	2	1 unweighted core elective
HPR1011: CPR for Professionals	0.5	1 unweighted core elective
EMS1070: EMT Clinical	1	1 unweighted core elective

## Teacher Cadet Program at Discovery Canyon High School and Village High School



The Teacher Cadet Program (housed at DCCHS and VHS) is open to 11<sup>th</sup> and 12<sup>th</sup> grade students. Teacher Cadet uses an innovative approach designed to attract talented young people to the teaching profession through a challenging introduction to teaching. The program seeks to provide high school students with insight into the nature of teaching, the problems of schooling, and the critical issues affecting the quality of education in America's schools. Students in the Teacher Cadet program participate in a six-week mini-teaching internship, a professional shadow experience, and observations of learners at all age groups.

**College Credit:** Students may earn the following college credit through UCCS for successfully completing high school Teacher Cadet courses:

- Teacher Cadet I is transcribed at UCCS as LEAD1000: American Foundations of Education
- Teacher Cadet II is transcribed at UCCS as EDUC2000: Intro to Educational Psychology

The courses above are not listed in the TREP (Teacher Recruitment and Education Program) Educator Pathway list, but for students hoping to apply as TREP students through UCCS, either Teacher Cadet course is qualifying as long as students receive the UCCS credit and provide a UCCS transcript.

The high school Teacher Cadet instructor receives student registration instructions from the university for their approved courses, as Teacher Cadet is categorized as a CU Succeed course. The teacher will distribute these guidelines to their students in the spring for year-long classes. To receive college credit, students must register by the UCCS published deadline. These college credits will only be recorded on the UCCS transcript, which students can order via the additional information linked below.

See the following for additional information:

UCCS Online and Academic Outreach  
<https://outreach.uccs.edu/cu-succeed>

gtPathways (Guaranteed Transfer) <https://higher.ed.colorado.gov/students/attending-college/credit-transfer/guaranteed-transfer-gt-pathways-general-education>

How to request a UCCS transcript  
<https://registrar.uccs.edu/transcripts>

Teacher Cadet Program  
<https://www.teachercadets.com>

## Project Lead the Way (PLTW) Programs in Engineering and Biomedical Sciences



Academy District 20 offers several site-based CTE pathways throughout the district that utilize the PLTW curriculum:

### **Engineering Programs**

- Air Academy High School
- Discovery Canyon Campus High School

### **Biomedical Sciences Programs**

- Discovery Canyon Campus High School
- Pine Creek High School

**PLTW Engineering** empowers students to step into the role of an engineer, adopt a problem-solving mindset, and make the leap from dreamers to doers. PLTW courses engage students in compelling, real-world challenges that help them become better collaborators and thinkers. Students gain in-demand knowledge and skills they will use in high school and for the rest of their lives, on any career path they take.

By immersing students in activities like practicing suturing and constructing body structures from clay, **PLTW Biomedical Science** empowers students to build knowledge and skills in biomedical science, as well as in-demand, transportable skills like problem solving, critical and creative thinking, communication, and collaboration.

**College Credit:** Students may earn college credit through UCCS for successfully completing high school PLTW courses. Some courses may transfer to other institutions of higher education within Colorado. The student is responsible for researching transferability.

High school PLTW teachers receive student registration instructions from the university for their approved courses. Teachers will distribute these guidelines to their students in the spring for year-long classes. To receive college credit, students must register by UCCS' published deadline. These college credits will only be recorded on the UCCS transcript, which students can order via additional information linked below. A list of PLTW courses being offered at D20 campuses is included in **Appendix D**.

See the following for additional information:

Project Lead the Way  
<https://www.pltw.org/>

UCCS Project Lead the Way  
<https://outreach.uccs.edu/pltw>

UCCS Online and Academic Outreach

<https://outreach.uccs.edu/cu-succeed>

gtPathways (Guaranteed Transfer) <https://highered.colorado.gov/students/attending-college/credit-transfer/guaranteed-transfer-gt-pathways-general-education>

How to request a UCCS transcript

<https://registrar.uccs.edu/transcripts>

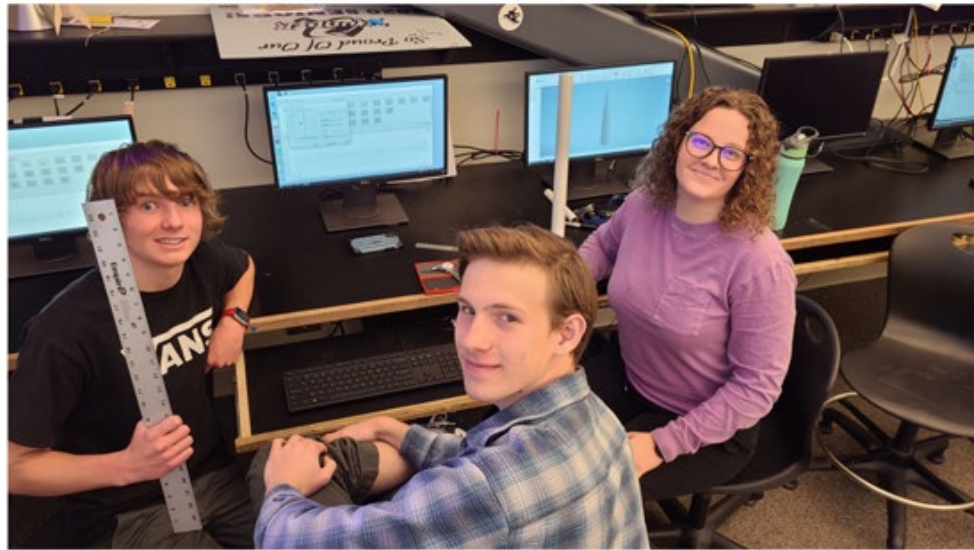
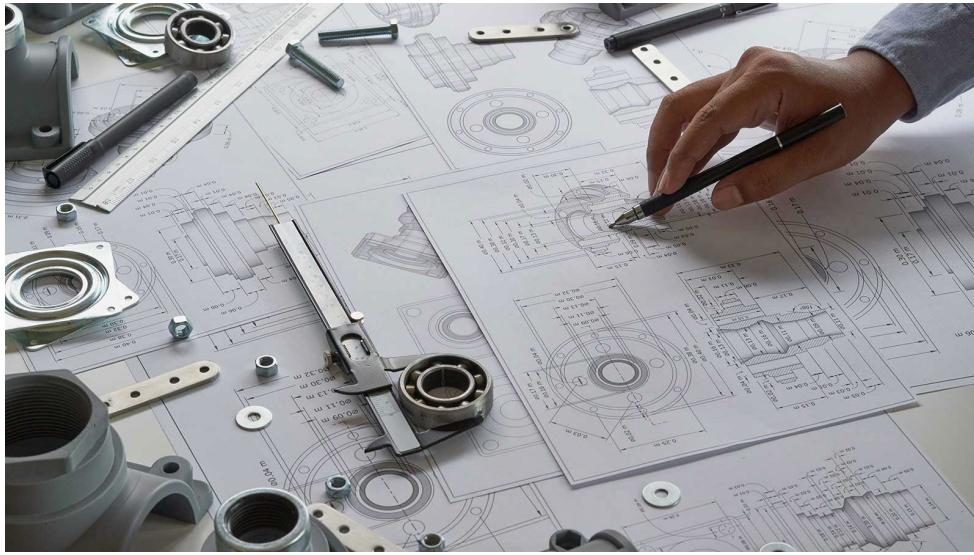

## Work-Based Learning (WBL) Opportunities

Work-Based Learning is a continuum of activities that begins with experiences that help one learn *about* work (such as career fairs, career presentations, career interviews), then progresses to learning *through* work (job shadows, internships, clinicals, etc.), and finally the student engages in learning *at* work (on-the-job training and apprenticeships). For the best experience, students need to start broad and gradually narrow their focus. For example, a student that expressed interest in STEM careers as a middle schooler may, through a series of career exploration activities, identify that they are specifically interested in mechanical engineering by their senior year in high school. Or maybe a student who loves reading and writing is slowly able to reveal a deep interest in journalism. Whatever the interest is, there are Work-Based Learning opportunities out there that would help the student get some much-needed real world experience under their belt.

Students who wish to participate in off-site, unsupervised WBL opportunities, such as job shadows or internships, will follow one of two paths, depending on whether or not they are enrolled in a career and technical education (CTE) pathway.

**Students who are enrolled in a CTE pathway** may have work-based learning experiences embedded in their pathway and will have opportunities to participate in additional Work-Based Learning activities that are teacher-sponsored and/or District-sponsored.

**Students who are not enrolled in a CTE pathway** will work with the high school site's Work-Based Learning Liaison or their teacher to utilize the opportunities listed through District resources or the Pikes Peak Business and Education Alliance (PPBEA). In all cases, it is best practice to follow the continuum. For more information about work-based learning, please speak with your CTE pathway teacher or your site's designated WBL Liaison, generally the College & College Counselor.

### Work-Based Learning Procedures

#### **Work-Based Learning Continuum Activities—On Campus, Supervised**

Work-Based Learning continuum of activities do not require an application and the completion of the enclosed paperwork in this manual **if** those activities are short in duration and/or students remain on school premises under teacher supervision (i.e. on-site career awareness and exploration activities, guest speakers, informal/mock interviews, on-site career fairs, school-based enterprises, etc.). Please follow your site policies for guest speakers and other activities where community partners are interacting with supervised students.

A good instructional practice for on-campus supervised WBL activities is to have writing prompts and other related activities, so students can reflect upon their experience and how it relates to the class curriculum, ICAP, and their college and career readiness.

#### **Work-Based Learning Continuum Activities—Off Campus, Supervised**

WBL activities off campus such as off-site career fairs and industry/worksite tours, and industry sponsored projects, as examples, need to follow activity/field trip procedures as outlined in Academy District 20 Administrative Policies Section I: IJOA-E (Activity/Field Trip Information Guide) and IJOA-R (Field Trip Procedures).

As mentioned previously, a good instructional practice for off-campus supervised WBL activities is to have writing prompts and other related activities, so students can reflect upon their experience and how it relates to the class curriculum, ICAP, and their college and career readiness.

### **Work-Based Learning Continuum Activities—Off Campus, Unsupervised**

Off campus unsupervised WBL activities include job shadows, clinical/field experience, credit for work experience, industry sponsored projects, internships, pre-apprenticeships/apprenticeships, and on-the-job training. These activities or programs usually have the student in the industry/workplace unsupervised by their teacher but work directly with industry partners. Some programs have their own specific requirements and procedures (such as SWAP & pre-apprenticeship/apprenticeship programs). Please contact your teacher or those specific programs for their procedures in addition to Academy District 20 procedures. There are requirements around documentation, ICAP alignment, and post-opportunity reflection activities for off campus, unsupervised WBL activities.

There are two main paths to securing off campus, unsupervised WBL opportunities:

- 1) Through the WBL Lead at the school site, the College and Career Counselor, CTE pathway teacher, or Academy District 20's WBL Coordinator.
- 2) Through Pikes Peak Business and Education Alliance (PPBEA), a regional WBL tool and website. Opportunities utilizing PPBEA should be initiated through the site WBL Liaison, College and Career Counselor, or teacher.

In all cases, it is best practice to follow the continuum. This means that students should complete a job shadow prior to applying for an internship, preferably completing both within the same industry and with the same industry partner.

Please note, placement in an unsupervised WBL experience is at the discretion of the industry partner/place of business and are often competitive and may require additional steps with the industry partner, such as formal interviews.

Additionally, students must meet a set of criteria before participating. The qualifications below ensure the student is prepared for the unsupervised experience, that both the students and the industry partner understand what is required of them, and that student safety and expectations of professionalism in a place of business are honored and respected.

#### **Student WBL Criteria:**

In order to qualify for participation in off-site, unsupervised WBL experiences, students must:

- be passing (no F's) all current and previous semester courses.
- have good citizenship and behavior and not under any current school disciplinary actions.
- have good attendance (no truancy issues) for current and prior semesters.

Note: The industry in which the student is hoping to participate in a Work-Based Learning opportunity should align with the student’s individual career and academic plan (ICAP).

Below is a table with a step-by-step process for WBL sponsored by the school district versus WBL sponsored by PPBEA.

Academy District 20 Sponsored WBL	PPBEA Sponsored WBL
<ul style="list-style-type: none"> <li>□ Student and teacher or site WBL Lead connect regarding desired or recommended WBL opportunity. If appropriate, student is given ok and provided with link to application. Ensure WBL Continuum is followed.</li> <li>□ Student completes the D20 Student WBL Application. The application includes District-required worker’s compensation documentation and media releases. The application will progress from student → parent/guardian → site sponsor (college and career counselor or teacher) → District WBL Coordinator. Student should not begin placement until after all steps have been completed. Student and parent/guardian will automatically receive a copy of finalized application. All approved applications will be uploaded into the student’s Infinite Campus account, in the Vocational Education tab documents.</li> <li>□ School site sponsor, student or parent/guardian, or D20 WBL Coordinator secures an opportunity for the student(s) and/or interview with industry partner (if required).</li> <li>□ After completion of the off-site WBL experience, the student should complete a Student Reflection Form (example on page of WBL Program Guide). *</li> <li>□ For job shadows and internships, Industry Partner may be prompted to complete the Industry Partner WBL Evaluation of Student Form and the Industry Partner WBL Experience Evaluation Form. *</li> </ul>	<ul style="list-style-type: none"> <li>□ Student and teacher or site WBL Lead connect regarding desired or recommended WBL opportunity. If appropriate, student is given ok and provided with link to application. Ensure WBL Continuum is followed.</li> <li>□ Student completes the ASD20 Student WBL Application. The application includes District-required worker’s compensation documentation and media releases. The application will progress from student → parent/guardian → site sponsor (college and career counselor or teacher) → District WBL Coordinator. Student should not begin placement until after all steps have been completed. Student and parent/guardian will automatically receive a copy of finalized application. All approved applications will be uploaded into the student’s Infinite Campus account, in the Vocational Education tab documents.</li> <li>□ Student creates a basic &amp; expanded profile on PPBEA website (see PPBEA section in this manual).</li> <li>□ Student and parent/guardian complete PPBEA acknowledgement documents.</li> <li>□ Student completes the PPBEA online Professionalism 101 course.</li> <li>□ Student connects their PPBEA profile to their school-based sponsor.</li> <li>□ Student applies for opportunity in PPBEA Marketplace (if meets minimum requirements).</li> <li>□ Student is accepted and referred for placement or is interviewed for placement by industry partner.</li> <li>□ Student maintains PPBEA time sheet throughout experience (digital copy to district CCS Dept. *).</li> <li>□ PPBEA Performance evaluation is completed by hosting industry partner and student (1 for every 60 hours).</li> </ul>

\* Digital copies of all D20 WBL forms and time logs must be returned the D20 WBL Coordinator.

- PPBEA quality survey is sent to student, hosting industry partner, and school-based sponsor).

\* D20 WBL Coordinator must have a complete digital copy of the time sheet and performance evaluations.

See the following for additional resources and information:

Colorado State Work-Based Learning website:

<http://coloradostateplan.com/educator/work-based-learning/>

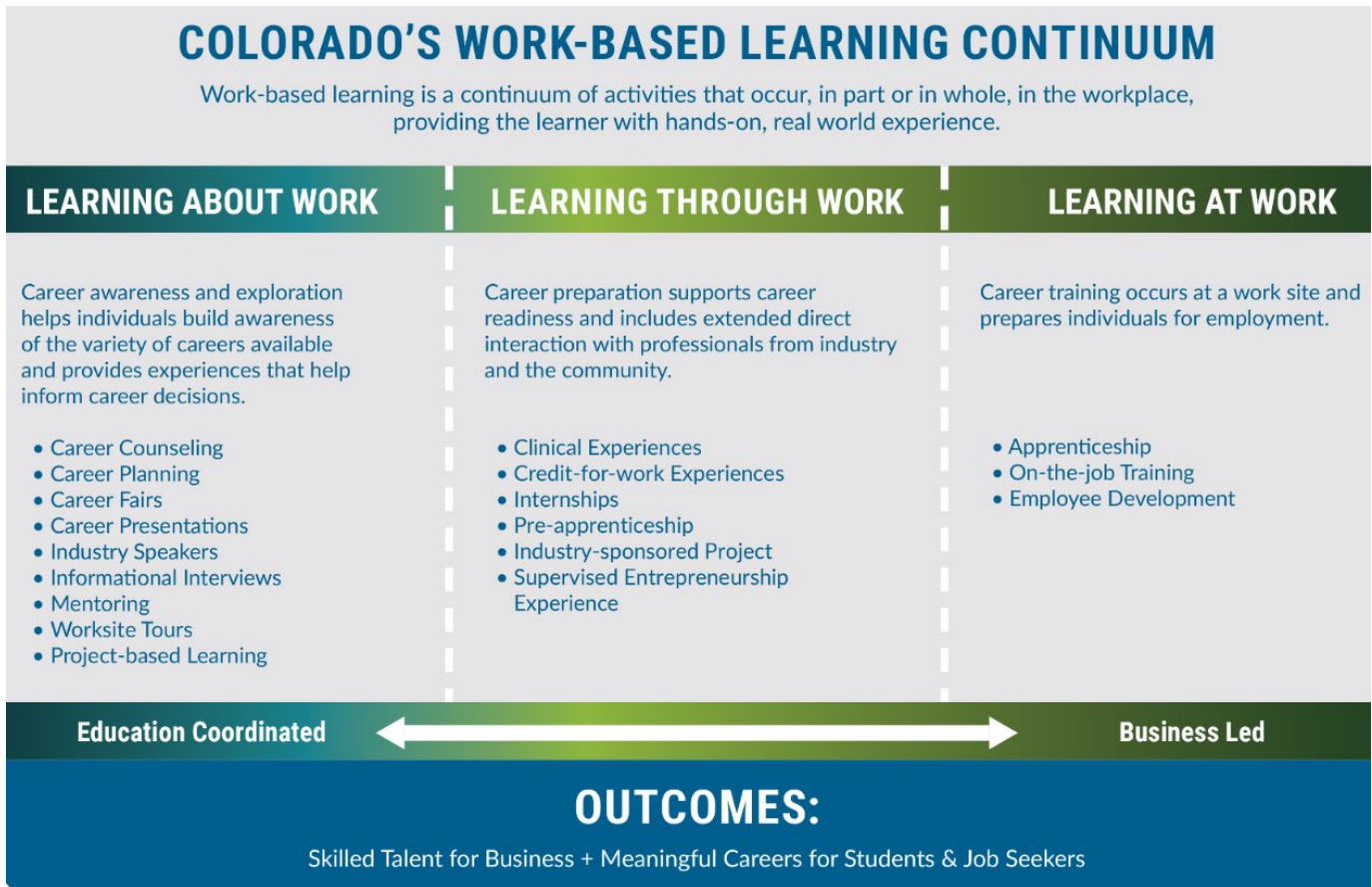



## School to Work Alliance Program (SWAP)

The School to Work Alliance Program (SWAP) is a collaborative initiative between the Colorado Division of Vocational Rehabilitation (DVR) and local school districts/Board of Cooperative Educational Services (BOCES), and is supported by the Colorado Department of Education (CDE). SWAP provides case management and direct services to **young adults with disabilities** who:

- Are eligible to receive DVR services (meeting disability documentation requirements and able to benefit from the program); and
- Have mild to moderate needs in employment;
- Need support in developing vocational awareness, career exploration, and experiencing career and employment opportunities to become competitively employed and to achieve successful outcomes.

**Purpose of SWAP:** The purpose of SWAP is to assist young adults in making the transition from school to employment, provide successful employment outcomes, increase community linkages, and new patterns of service for young adults within all categories of disabilities. The program's goals include:

- Building on current transition planning efforts;
- Creating a career pathway through pre-employment transition services;
- Filling the case management gap for the targeted population; and
- Supporting collaboration between DVR and local school districts/BOCES.

SWAP is intended to provide employment-related assistance to young adults with disabilities, who are experiencing mild to moderate barriers to employment. Disabilities can include but are not limited to physical, emotional, or learning disabilities. SWAP provides opportunities for young adults to practice and improve workplace skills, consider their career interests, and obtain real world work experience that will lead to competitive, integrated employment in today's high demand industries.

**SWAP Services:** Young adults potentially eligible or eligible for services provided through DVR, qualify to receive evaluation and diagnostic services, vocational counseling and guidance, physical and mental restoration services, and training. Additionally, SWAP may provide services such as:

- Pre-employment transition services
- Career exploration
- Career development
- Employment-related instruction
- Job development / placement
- Case management
- One year of follow-up
- Year-round community-based services

**SWAP may provide services when appropriate to:**

- Eligible applicants for DVR services, and

- Young adults between the ages of 15-24, and
- Have mild to moderate needs in employment, and
- Typically living within the boundaries of a school district/BOCES participating in the SWAP program. Young adults who do not live in a participating district/BOCES may access vocational rehabilitation services directly through DVR.

**Young Adults could be:**

- In-School:
  - Person with a disability under 504 of the Americans with Disability Act
  - Receiving special education services
  - Suspected or known disability not under any other category
- Out-of-School
  - Graduated or aged out
  - Drop-out or at risk of dropping out
  - Unemployed or underemployed

**SWAP would not be appropriate for:**

- Middle school aged students or younger
- Young adults with significant needs who will require extensive services or currently are eligible for supported employment services
- Young adults with on-going legal problems that make placement in a work setting difficult

**Academy District 20 SWAP Contacts (SWAP Coordinators):**

- Michelle Casner, 719-234-1377, [michelle.casner@asd20.org](mailto:michelle.casner@asd20.org)
- Morgan Markewich, 719-234-1369, [morgan.markewich@asd20.org](mailto:morgan.markewich@asd20.org)

# Concurrent/Dual Enrollment College Credit Opportunities

## College Credit for Courses Taken During High School

What are some reasons you might consider Concurrent Enrollment? Here are some of the best reasons cited on the Colorado Department of Education Concurrent Enrollment Website:

<http://www.cde.state.co.us/concurrentenrollment/options-concurrentenrollment>

**No tuition cost to you**—The school district covers the cost of tuition; for most courses and programs, students and families pay for books and fees.

**Save money and time on college**—By taking Concurrent Enrollment courses while in high school at no tuition cost, you save money and time by not having to take and pay for those courses when you enroll in college after high school graduation. Learn more about the costs of college here:

<http://www.cde.state.co.us/concurrentenrollment/collegecost>

**Guaranteed credit transfer**—Many Concurrent Enrollment classes are guaranteed to transfer to any public institution within the state of Colorado. However, while courses transfer, it is still important to determine if they will apply to your college degree or certificate. Learn more about the transfer of credits here: <http://www.cde.state.co.us/concurrentenrollment/transfercredits>

**Convenience**—Some of our college-credit bearing classes are taught in District 20 high schools! This means that these classes may fit into your high school schedule, and you don't have to own a car and drive to a college campus to earn credit.

**Build up your confidence**—Counselors report that students who are nervous about taking a college class end up being more confident once they pass because they know they can be successful in college.

**Opportunities to earn industry-based certifications**— When you take CTE Concurrent or Dual Enrollment courses, you have the opportunity to earn industry-based certifications, which are recognized by local and national workforce agencies and indicate a student has developed the skills necessary to be successful in this competitive workforce.

**Students are successful**—Data from the Colorado Department of Higher Education and the Colorado State Board for Community Colleges and Occupational Education show over 90% of students who take Concurrent Enrollment courses pass with a C or better.



## Concurrent Enrollment at University of Colorado Colorado Springs (UCCS), Metropolitan State University of Denver (MSU Denver), or Pikes Peak State College (PPSC)

College-ready high school students can apply for a course at UCCS, MSU Denver, or PPSC and earn high school and college credit. All courses must be pre-approved by the student's high school counselor and by College and Career Services to qualify for Concurrent Enrollment. Only in-person UCCS courses will be approved for Concurrent Enrollment; only online courses are approved at MSUD. PPSC courses are typically only approved in-person, but requests for online CE courses through PPSC may be considered on a case-by-case basis.

Courses that are listed on the university/college's GT (guaranteed transfer) list must align with a student's ICAP plan. **Course credits must (i) apply to the completion of high school graduation requirements; (ii) be approved by the Department of Higher Education for transfer from a two-year institution to a four-year institution in satisfaction of prerequisite courses for a specific major; (iii) be approved for statewide transfer, or be part of a statewide degree transfer agreement; or (iv) apply toward an approved postsecondary career and technical education program.**

*If a college course is not GT (guaranteed transfer), the student must provide documentation from their college of choice that the course is a prerequisite for the student's intended college major, as referenced in the student's ICAP.* The courses on these lists are subject to change and may not reflect all GT courses offered and available as concurrent enrollment at the university/college. It is important that students research how individual courses may benefit them in their postsecondary endeavors.

Consider the following before applying for concurrent enrollment:

- At the time of your application, you will need to know which specific course(s) at UCCS, MSU Denver, or PPSC you intend to take. As you consider the courses you want to request, be sure to double-check the course catalog at your desired institution to ensure you meet (or will meet) prerequisites for the course. **Appendices A, C and E** contain lists of PPSC, UCCS, and MSU Denver courses that are eligible to be considered for concurrent enrollment. This list is current as of this writing but is subject to change based on course availability and transferability.
- After the application closes, you will be notified via email as to the status of your application. If you have been accepted into a course or program, it is your responsibility to follow through with applying for the relevant course or program at the college or university.
- Please note that the grades you earn in your classes will be recorded on both your high school and

college transcripts, and that college courses will impact your high school GPA. See the following for additional information for guidance in concurrent enrollment requirements.

## D20 Concurrent Enrollment Guidelines

### Student Completes Individual Career and Academic Plan (ICAP)

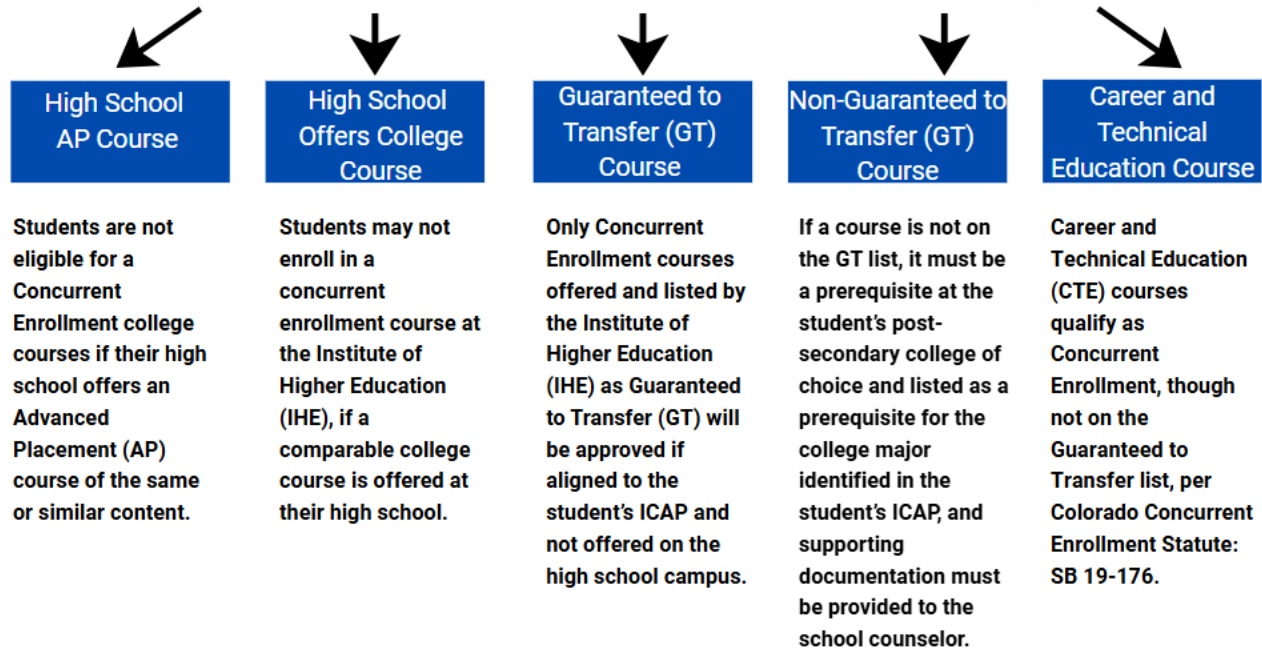

UCCS Concurrent Enrollment/Non-Degree Application  
<https://www.uccs.edu/admissions-aid/application-details/non-degree>

Concurrent Enrollment or Dual Enrollment at MSU Denver  
<https://www.msudenver.edu/innovative-lifelong-learning/college-credit-in-high-school/dual-enrollment/>

PPSC High School Programs  
<https://www.pikespeak.edu/academics/high-school-programs/>

PPSC Placement Test Preparation Resources  
<https://www.pikespeak.edu/academics/learning-commons/tutoring/>

Academy District 20 Administrative Policy IHEDA: Concurrent Enrollment  
<https://go.boarddocs.com/co/asd20/Board.nsf/goto?open&id=BUUSSL74195C>

### Applying for Concurrent/Dual Enrollment or “Center of Excellence” Districtwide CTE Programs

The following chart provides an overview of the programs available in the district, the grade levels at which students may participate, and the process students should follow to apply. More detailed information on each program can be found in the sections that follow. Most programs listed here use the CCS Application.

<b>Program</b>	<b>Location</b>	<b>Type of Credit</b>	<b>Eligible Grade Levels</b>	<b>Student Costs</b>	<b>Application Process</b>
<b>Automotive Service Technology</b>	Liberty High School	High School	11, 12	See school fee schedule	CCS Application (D20)
<b>Building Construction Technology</b>	Liberty High School	High School	11, 12	See school fee schedule	CCS Application (D20)
<b>Career Start</b>	Pikes Peak State College	High School and College	11 and 12	N/A*	CCS Application (D20) PPSC and Career Start Application processes at the college
<b>Certified Nurse Assistant and Emergency Medical Technician Programs</b>	Liberty High School	High School and College (PPSC)	11 and 12 (12 <sup>th</sup> only for EMT)	student-specific supplies and course fees	CCS Application (D20)
<b>Concurrent Enrollment</b>	UCCS (in person), MSU Denver (online), PPSC (in person)	High School and College	9, 10, 11, 12	Books, fees, course-specific supplies	CCS Application (D20) College application/registration process
<b>CU Succeed</b>	Air Academy HS Aspen Valley HS Discovery Canyon HS Pine Creek HS Village HS	High School with a College Credit Option (UCCS)	9, 10, 11, 12	All tuition and fees	Registration available to students enrolled in the high schools offering programs
<b>Dual Enrollment (CU Succeed Platinum)</b>	University of Colorado Colorado Springs	High School and College (UCCS )	9, 10, 11, 12	Books, fees, course-specific supplies	CCS Application (D20) University application/registration process
<b>MathOnline (UCCS)</b>	University of Colorado Colorado Springs	High School and College	11 and 12	Partial tuition, books, fees (D20 pays the community college tuition rate per credit hour)	CCS Application (D20) University application/registration process
<b>Project Lead the Way (PLTW) Programs in Engineering and</b>	Discovery Canyon Campus High School, Air Academy High	High School with a College Credit	9, 10, 11, 12	All tuition and fees	Registration available to students enrolled in the high schools offering programs

<b>Biomedical Science</b>	School, Pine Creek High School	Option (UCCS)				
<b>Rampart Early College Academy (RECA)</b>	Rampart High School	High School and College (UCCS)	9,10,11, 12	N/A*		High School Based Application (In most cases, students must enter the RECA program as 9 <sup>th</sup> graders)
<b>Teacher Cadet</b>	Discovery Canyon Campus High School, Village High School	High School with a College Credit Option (UCCS)	11 and 12	See school fee schedule		High School Based Application

\*District 20 covers the cost of tuition, books, and program-specific fees (such as lab supplies) for these programs; however, any additional costs or college fees are the responsibility of the students and/or their parents/guardians.

## College Opportunities Checklist

Please review this checklist before pursuing college credit opportunities.

### Evaluate Whether You Meet Eligibility Requirements

In most cases, applications to participate in postsecondary opportunities will only be approved for students who meet the following criteria:

- No grades lower than a “C” for the previous semester and current semester of high school coursework (and college coursework when applicable)
- No grades lower than a “B” for the previous semester and current semester in the high school content area for which the student is applying to take advanced coursework
- On-track for graduation and not in need of remedial coursework
- Up-to-date with high school ICAP goals that are aligned to postsecondary planning

### Meet with your School Counselor or Administrator

Your counselor can share information about concurrent/dual enrollment and CTE courses and programs that are aligned to your postsecondary plan. Your counselor can also advise you regarding options for best meeting District 20 graduation requirements while pursuing opportunities that align with your passions.

Please keep the following District 20 Graduation Requirements in mind as you consider your college and career coursework opportunities:

## Academy District 20 Graduation Requirements

Requirements	Credits	Special Notes
English	8	
Science	6	Four of the six credits must be from laboratory science classes.
Mathematics	6	All students must complete Algebra 1 and Geometry (either in middle school or in high school). All students must earn 6 math credits during grades 9-12.
Social Science	6	Social Science requirements include two required credits of U.S. History and one credit of Civics, and two required credits of *World History or another course covering Holocaust and Genocide studies as required by House Bill 20-1336.
World Language	2	High school level world language courses taken in middle school may apply to this requirement but will not count toward the requirement of 50 total credits. When applying middle school world language credits to meet this requirement, two additional core elective credits must be earned.
Core Electives	6	Core elective requirements include courses in English, world language, mathematics, science, and social science.
Physical Education	3	
Health	1	
Arts	1	Arts requirements include visual and performing arts.
Unrestricted Electives	11	Credits earned beyond the requirements listed above will count as unrestricted elective credit.
<b>Total</b>	<b>50</b>	

\*Beginning with the ninth-grade class of 2024-25, World History or another course covering Holocaust and Genocide studies as required by House Bill 20-1336 will become a requirement for graduation.

### Update your Individual Career and Academic Plan (ICAP) with your Counselor

Your counselor will examine your ICAP to approve moving forward with postsecondary or CTE courses or moving forward with other challenging courses. If you are approved to apply for advanced opportunities, your requested program or courses **must** be in alignment with your ICAP goals.

### Complete Assessment Testing

Colleges require that students meet prerequisites prior to enrolling in courses. Talk to your counselor and the college about testing accommodations and any course prerequisites that may be required. Please access information on testing and prerequisites at the following website:

- PPSC: <https://www.pikespeak.edu/admissions/testing-center/placement-testing/>
- MSU Denver: <https://www.msudenver.edu/testing/>
- UCCS: <https://testingcenter.uccs.edu/faq>

**Complete your District 20 Application**

Unless otherwise noted above, complete the online CCS Application. The application is due on or before **March 1<sup>st</sup>** for fall semester and year-long programs. Applications for courses beginning in the spring semester will be due on or before **October 1<sup>st</sup>**. Be sure to select the correct semester when completing the application process, and note that there is a course change approval process for students who are approved for a course or program but would like to make one or more adjustments to their schedule.

Programs that have application processes managed at the high school level may have different due dates and processes, so be sure to check with the school hosting the program to ensure you are meeting deadlines.

**Complete your College Application**

For programs outside of District 20, students who have been approved by the district must apply to the school they plan to attend. Meet with your counselor or school administrator to make sure the application(s) is (are) completed correctly.

**Sign up for the College Opportunity Fund (if taking classes that are COF eligible)**

The College Opportunity Fund (COF) stipend pays a portion of your total in-state tuition when you attend a Colorado public institution or a participating private institution. The stipend is paid on a per credit hour basis to the institution at which you are enrolled and will be deducted from the designated COF account. For students taking concurrent enrollment coursework, registering for COF is a requirement of participation. Students taking dual enrollment courses (CU Succeed, PLTW, and/or MathOnline) do not need to apply for COF unless they are also taking concurrent enrollment. Access the COF application here: <https://cof.college-assist.org/Apply>

**Register for College Course(s) by established deadlines**

Once you have completed this checklist, you will need to register for your college course(s), pay any fees (if applicable), and purchase your textbooks. Please note that managing the application and enrollment process at the college or university is the responsibility of the student. Neither district personnel nor high school counselors have access to students' college/university accounts or portals.

Information about how to register will be available in your D20 Student Hub College and Career Button. You can access the student Hub by simply opening a browser on a D20 device or navigate there by going to [www.asd20.org](http://www.asd20.org) > Logins > Student > Student Hub.

Students should **register for fall college courses by May 1<sup>st</sup>** or **as soon as possible** based on catalog and registration availability and should **register for spring college courses no later than December 1<sup>st</sup>**. Failure to meet these deadlines may impact course availability and ultimately a student's ability to take sponsored college courses in a given semester.

In addition to the checklist above, please review the program-specific information for the course or program to which you are applying.

## District 20 General Concurrent and Dual College Enrollment Guidelines

- A. The student should seek advice and counsel from his or her high school about pursuing college-level work.
- B. A student's course load cannot exceed 8 combined classes between their high school courses and concurrent enrollment courses. Students must meet the required grade-level on-campus course enrollment at their high school (Board Policy: IHEDA). Interest in taking beyond 8 courses in their schedule requires a principal and CCS director's approval.
- C. Students are expected to maintain full-time status while enrolled in a D20 high school and participating in concurrent and/or dual enrollment. This may be accomplished through a combination of high school and college courses. Students participating in college courses must enroll in a minimum number of high school courses in each semester during which they participate in CE or DE. These minimums are: 9<sup>th</sup> grade, 6 classes; 10<sup>th</sup> and 11<sup>th</sup> grades, 4 classes; and 12<sup>th</sup> grade, 2 classes.
- D. The student must apply for the College Opportunity Fund (COF) before enrolling in concurrent enrollment. This can be done online at <https://cof.college-assist.org/>.
- E. The student must authorize use of his or her COF stipend for all eligible credits. College-level credits used will be deducted from the Student's COF lifetime account. D20 will not pay tuition that could be covered by COF, so students who fail to apply for this stipend may be billed by the college or university.
- F. The student must meet the same prerequisites and course expectations as all other college students in a course, as noted in the institution of higher education's catalog and the course syllabus. If a student is approved for a course or sequence of courses but is subsequently unable to meet prerequisites at the college or university, the student's approval is presumed to be rescinded. The student may not simply enroll in a different course for which qualifications are met unless prior approval is received via a course change request.
- G. Grades earned in college courses taken through concurrent or dual enrollment will appear on the student's official high school and college transcript each semester, and all college courses will impact HS GPA as outlined in policy IAAA R.
- H. Courses that the student completes at the college or university will be weighted on the student's high school transcript if they meet the following criteria:
- a. The student completed the course with a "C" or better
  - b. The course is worth at least 3 credit hours
  - c. The course is on the guaranteed transfer list for the state of Colorado and identified as guaranteed to transfer for the specific college/university.
- I. College course credits may transfer in congruence with Colorado Guaranteed Transfer (GT) Pathways or articulation agreements if the student earns a "C" or better in the course. It is the responsibility of students and families to research transferability.

J. If the student seeks to add, drop, or withdraw from a college course, he or she must meet with the high school counselor, submit the Concurrent/Dual Enrollment Course Change Request Form, and complete the drop/withdrawal process at the college or university. Only courses approved through the initial application, or the Course Change Request process will be sponsored. If a student enrolls in any class that is not approved by D20, the course will not be sponsored, and the student/family will be responsible for any tuition, fees, or other expenses.

K. If the student receives a grade of D or F or withdraws from a course after the college drop deadline the D/F/WF grade will appear on the student’s high school and college transcripts.

L. Any student earning a grade of D, F, or W in a college course will be ineligible to participate in district-sponsored college coursework in the subsequent semester. Eligibility may be reinstated after one semester not enrolled in concurrent enrollment courses.

M. The student is responsible for applying for admission to the college, registering for college courses, and monitoring progress.

N. Parents/Guardians will have no access to the student’s college records, including grades, attendance, and disciplinary actions unless the student has signed the appropriate waiver, which may only be obtained from the college.

O. For an approved Concurrent Enrollment student, D20 shall pay, directly to the institution of higher learning, the tuition for online and/or on-campus courses (please note that online CE courses are typically only approvable at MSU Denver). For an approved Dual Enrollment student, D20 shall only pay directly to the institution of higher learning, the prevailing community college on-campus tuition rate with COF applied. This rate applies for online and on-campus courses and does not include fees, books, supplies, or any tuition costs in excess of the rate mentioned above.

P. The Student shall pay to the institution of higher learning any *additional costs not covered by D20* to include campus fees, course fees, books, supplies, and tuition beyond what is covered by D20 as outlined above. The student shall also pay all tuition and fees for any courses not specifically approved for concurrent/dual enrollment via the application or course change request process.

Q. Home School Academy Students (HSA) are eligible to enroll in two concurrent enrollment courses a semester.

### **High School Credit and Weighting for College Coursework**

College coursework taken by high school students will be transcribed at the high school level using the following conversion:

<b>College Credit Hours</b>	<b>High School Credits</b>
1-2	1
3+	2

District 20 policy regarding weighted credit for college courses was updated on July 1, 2023. College coursework on the Guaranteed Transfer (GT) list for the state of Colorado and identified as GT for a specific university/college, college courses at the 300/3000 level or higher (or equivalent), or courses offered by a four-year university that are district approved due to being a pre-requisite for a specific university's college major and aligns to the student's ICAP shall be weighted. The following categories are exceptions and are not weighted:



- A developmental or remedial course
- A course less than 3 credit hours of college credit
- Physical education courses, outdoor education courses, or recreational education courses
- Career and technical education courses (PPSC)

### **Rampart Early College Academy (at Rampart High School)**

Rampart Early College Academy (RECA) is an innovative answer to students desiring to be in a rigorous academic program, earning college credit which can be used to meet post-secondary degree requirements, while still being a regular high school student participating in sports, band, theater, choir, career & technical education (CTE) programs, clubs, etc. Many “early college” programs throughout the Pikes Peak region require students desiring to take college coursework integrated into their high school program, to enroll in an alternative school setting separate from their comprehensive high school. RECA will enable its students to be regular Rampart High School students, with access to the other academic programs and co/extra-curricular activities.

Students accepted into RECA may have the opportunity to earn up to 30 college credits through the University of Colorado Colorado Springs during their four years in high school with no tuition costs. This will help students meet many undergraduate education requirements for most bachelor's degrees before ever graduating from high school. Students will have access to Rampart's AP courses in addition to concurrent and dual enrollment through UCCS, MSU Denver, and PPSC.

A critical component to RECA is building a sense of community and support. All RECA students will also take part in AVID—Advanced Via Individual Determination program courses. AVID develops study skills, provides academic support, college and career exploration, and college preparation. A gradual increase in college coursework over a student's high school experience, with AVID support, is a proven recipe for academic success and college preparation!

Application process for Rampart's AVID/RECA program:

**For students who attend Mountain Ridge Middle School**, there will be an informational letter sent home to current 8<sup>th</sup> graders with the opportunity to attend a parent and student AVID/RECA information night in early January. For those who are interested, the parent/guardian will complete the application provided by RHS. and Rampart's AVID/RECA team will conduct brief

interviews at Mountain Ridge at the end of January. Program acceptance letters will be sent to students by March 1<sup>st</sup>.

**For School Choice students** who do not attend Mountain Ridge, please fill out the AVID/RECA application and email the application to the AVID Coordinator, Mrs. Brubaker ([bre.brubaker@asd20.org](mailto:bre.brubaker@asd20.org)). If Rampart High School is not a student's home school, please also complete the district's School Choice process (<https://www.asd20.org/school-choice/>). Program acceptance will be communicated by March 1<sup>st</sup>.

## **CU Succeed at a D20 High School**

Students may earn college credit for successfully completing select high school academic courses. Some courses may be guaranteed to transfer to public institutions of higher education within Colorado. The student is responsible to research transferability, but a list of courses that are currently on the state guaranteed transfer list is available in **Appendix C**. In addition, a list of the courses being offered at D20 high schools via CU Succeed is available in **Appendix D**.

High school teachers who are approved as University of Colorado instructors receive student registration instructions from the university for their approved courses. Teachers will distribute these guidelines to their students in the Spring for year-long classes. Students must register by UCCS's published deadline (usually in mid-March) to receive college credit. These college credits will only be recorded on the UCCS transcript, which students can request from the university.

**Cost:** Tuition and fees are the responsibility of students and parents.

**Deadlines:** These vary and are published in the registration instructions. Generally, for year-long courses, the registration deadline is mid-March and the withdrawal deadline (with penalty) is early May. See the following for additional information:

UCCS Online and Academic Outreach  
<https://outreach.uccs.edu/cu-succeed>

How to request a UCCS transcript  
<https://registrar.uccs.edu/transcripts>

gtPathways (Guaranteed Transfer)  
<https://highered.colorado.gov/students/attending-college/credit-transfer/guaranteed-transfer-gt-pathways-general-education>

## **UCCS Pre-Collegiate Development Program**

For more than 35 years, the University of Colorado Colorado Springs (UCCS) Pre-Collegiate Development Program has offered a free, multi-year academic enrichment program for prioritized middle and high school students. Its purpose is to motivate and prepare scholars from first-generation, low-income, and

military connected backgrounds in their pursuit of postsecondary goals. Pre-Collegiate prepares scholars to understand, enroll, and be successful in post-secondary education and in their chosen careers.

The high school program during the academic year consists of after school workshops. During these workshops, highly trained and experienced college students serve as instructors and mentors. The workshops focus on the development of valuable life skills such as financial literacy, career exploration, financial aid, scholarship opportunities, and navigating the postsecondary world. Multiple workshop topics and days are available, and students may choose to attend those that interest them and fit in with their schedules. All that is required is that they attend a minimum of one per month.

Pre-Collegiate also gives scholars the opportunity to participate in the College Experience Program. Through this program, they have opportunities to explore college and university campuses in the Pikes Peak region. During the tours, they hear from college students, faculty, and staff, and learn how to compare their options so they can make informed decisions later.

Everything the program offers is free of charge, but scholars and families are asked to commit to remaining in the program for the duration of their high school careers and communicate with Pre-Collegiate when they cannot attend programming. For more information, visit the Pre-Collegiate Development Program's website here: <https://pcssc.uccs.edu/cos/high-school>

## **Outside College Credit from Non-Sponsored District 20 Dual Enrollment**

Students may earn college credits outside of the concurrent and dual enrollment structures sponsored by District 20. Courses taken through District 20 sponsored concurrent and dual enrollment are not subject to the guidelines below. Students must use the form in D20 Administrative Policy IHADB E2 to apply for outside college level course(s) to be applied to their high school transcript. For high school level courses, students must submit the Outside High School Credit Application (IHADB E1).

1. College courses taken outside of the concurrent/dual enrollment structure must be approved by D20 College and Career Services prior to student enrollment. Courses completed without prior approval may be evaluated but are not guaranteed to be added to the high school transcript and may not be counted toward graduation requirements.
2. A student must be enrolled in District 20 as a full-time student before requesting credit from outside college courses.
3. All credit must be obtained from accredited colleges and/or universities. Requests for credits from non-accredited colleges or universities will be denied.
4. College courses taken outside of the concurrent/dual enrollment structure are not funded by District 20 or any individual high school.
5. For approved outside college credit, final decisions regarding the type and amount of high school credit and whether the course qualifies for GPA weight, are made by College and Career Services. (See policy IKAA-R Grading/Assessment Systems in the High Schools Procedure).
6. Once an approved outside college course is complete, it is the student's responsibility to provide College and Career Services with a transcript from the college or university that reports the final

grade for the course. Approved courses will not be added to student transcripts without this documentation.

To apply for outside college credit, access the application form on the College and Career page of the D20 website.

See **Appendices B, C, and E** for lists of courses from Pikes Peak Community College, the University of Colorado Colorado Springs, and Metropolitan State University of Denver that are on the state guaranteed-to-transfer list and may be considered for outside agency credit. These are not the only courses eligible for such credit, but they provide a good guide as to the types of courses that are approvable.

## University of Colorado Online (CU Succeed Platinum)

College-ready high school students can enroll in a college course that is offered online through the CU system to earn high school and college credit. Some courses may be guaranteed to transfer to public institutions of higher education within Colorado. The student is responsible for researching transferability. A list of courses that are currently on the state guaranteed transfer list is available in **Appendix C**.

The following courses are tentatively scheduled for the 2026-2027 and 2027-2028 academic years:

### UCCS Online Courses: 2026-2027

#### Fall

WEST1010 Intro to Social Justice Studies  
ANTH1040 Intro to Cultural Anthropology  
FNCE1200 Personal Financial Planning  
ASTR1090 Astronomy of the Solar System  
ECON1010 Intro to Microeconomics

#### Spring

COMM2100 Public Speaking  
MATH1040 College Algebra  
ECON2020 Intro to Macroeconomics

### UCCS Online Courses: 2027-2028

#### Fall

SOC1110 Intro to Sociology  
COMM1020 Interpersonal Communication  
PHIL1120 Critical Thinking

#### Spring

BIOL1000 Biology in the Modern World w/Lab  
COMM2010 Oral Comm in the Workplace  
MATH1050 Elementary Functions of Calculus

See the following for additional information:

CU Succeed Platinum

<https://outreach.uccs.edu/cu-succeed-platinum>

UCCS Online and Academic Outreach

<https://outreach.uccs.edu/cu-succeed>

gtPathways (Guaranteed Transfer)

<https://highered.colorado.gov/students/attending-college/credit-transfer/guaranteed-transfer-gt-pathways-general-education>

How to request a UCCS transcript

<https://registrar.uccs.edu/transcripts>

## MathOnline (UCCS)

MathOnline allows qualified high school students to enroll for credit in UCCS courses without having to physically be on campus. This program is specifically for students who are very advanced in mathematics and no longer have math courses available to them at the high school level. Most MathOnline courses run synchronous to the corresponding math courses (Fall and Spring semesters). This means that students are given access to the course through a dual video feed, one that captures the whiteboard and the other that focuses on the entire front of the class. This gives a very realistic feeling to the lectures. Students can attend lectures virtually in real time or watch the recording at their convenience.

The following courses offered through **MathOnline** are options for D20 students:

- MATH1360: Calculus II
- MATH2350: Calculus III
- MATH2150: Discrete Mathematics
- MATH3110: Theory of Numbers
- MATH3130: Introduction to Linear Algebra
- MATH3400: Introduction to Differential Equations
- MATH3410: Introduction to Analysis
- MATH3810: Introduction to Probability and Statistics

Please note that there is an out-of-pocket cost for students who enroll in MathOnline courses. D20 will pay the community college rate per credit hour for MathOnline courses, but the difference between that tuition rate and the UCCS tuition is the responsibility of students and families. In addition, families are responsible for any books and fees.

See the following for additional information:

Math Online: College of Letters, Arts, & Sciences

<https://mathonline.uccs.edu/>

MathOnline Course Schedule

[https://mathonline.uccs.edu/course\\_schedule](https://mathonline.uccs.edu/course_schedule)



## College Credit for International Baccalaureate (IB) Courses

The aim of IB programs is to develop internationally minded people who recognize their common humanity and shared guardianship of the planet. Central to this aim is international mindedness. International mindedness is a multifaceted

concept that captures a way of thinking, being, and acting characterized by an openness to the world and a recognition of our deep interconnectedness to others.

IB has four specific programs: the Diploma Programme (DP) which provide a challenging yet balanced education that facilitates geographical mobility by providing an internationally recognized university-entrance qualification, but that also serves the deeper purpose of promoting intercultural understanding and respect. The Middle Years Programme (MYP) and the Primary Years Programme (PYP) is the IB identified continuum of international education for students aged 3 to 19. Last, the Career-related Programme (CP) provides a choice of international education pathways for 16- to 19-year-old students.

Students may earn college credit for IB courses, but the amount of credit varies. Some colleges only award college credit to students who hold a full IB diploma, while most others award credit for individual exam scores (similar to AP). Please consult with your counselor and the desired college/university for their policy on college credit for IB courses.

IB programs are offered at the following Academy District 20 high schools:

- Discovery Canyon Campus High School  
<https://dcchigh.asd20.org/academics/international-baccalaureate/>
- Rampart High School  
<https://rampart.asd20.org/international-baccalaureate/ib-dp/>

See the following for additional information: IB Program Website <https://www.ibo.org/>

## College Credit for Advanced Placement (AP) Courses



The Advanced Placement Program enables willing and academically prepared students to pursue college-level studies while still in high school. The program consists of college-level courses developed by the AP Program that high schools can choose to offer, and corresponding exams that are administered once a year.

Many colleges offer credit for AP scores. Suppose a student earned a “4” on the AP Biology Exam, and the college they will attend grants them credit for the equivalent college course. That means the student will walk into college with credit under their belt—before they even take their first class there.

Please contact your desired college to see if they take AP credits and if so, what their minimum exam scores are. Please also reference your high school’s course catalog for current AP course offerings or refer to the table on the following page.

See the following for additional information:  
CollegeBoard AP website <https://apcentral.collegeboard.org/>

## Academy District 20 Advanced Placement Course Offerings

AP Course Offered	AAHS	DCCHS*	LHS	PCHS	RHS*	VHS
AP Studio Art	X			X	X	X
AP Studio Draw			X	X		
AP Art History	X					
AP English Lang and Comp	X		X	X	X	X
AP English Lit and Comp	X		X	X	X	
AP Latin			X			
AP French Language	X		X	X	X	X
AP French Language 2					X	
AP German Language	X			X		
AP Spanish Language	X		X	X	X	X
AP Spanish Language 2					X	
AP Chinese Language					X	
AP Chinese Language 2					X	
AP Calculus AB	X	X	X	X	X	X
AP Calculus BC	X	X	X	X	X	
AP Statistics	X	X	X	X	X	
AP Music Theory	X			X		
AP Biology	X		X	X	X	X
AP Environmental Science	X		X	X	X	X
AP Chemistry	X		X	X	X	X
AP Physics 1	X			X	X	
AP Physics C			X	X	X	
AP Economics			X			
AP Human Geography	X		X	X	X	X
AP European History	X		X	X	X	
AP US History	X	X	X	X	X	
AP World History (Modern)	X					
AP US Govnt and Politics	X		X		X	
AP Psychology	X		X	X	X	X
AP Computer Science				X		
AP Computer Sci. Principles				X		
AP Cybersecurity 1				X		

\* Discovery Canyon Campus High School and Rampart High School offer additional college credit opportunities through their respective International Baccalaureate (IB) programs.

## Appendix A

### Career Start at Pikes Peak State College: Credit Allocation

Program	Courses	College Credit Hours	High School Core Elective Credit
Auto Collision Technology I Fall	ACT1001: Introduction to Automotive Collision Technology	4	2
	ACT1042: Surface Preparation I	2	1
	ACT1043: Spray Equipment Operation	2	1
Auto Collision Technology I Spring	ACT1021: Non-Structural Repair & Replacements	3	2
	ACT1022: Panel Repair & Replacements	3	2
	ACT2032: Automotive Glass Repair	2	1
Auto Collision Technology II Fall	ACT1011: Metal Welding & Cutting I	3	2
	ACT1031: Structural Damage Diagnosis	3	2
	ACT1051: Plastics & Adhesives I	1	1
	ACT2051: Plastics & Adhesives II	1	1
Auto Collision Technology II Spring	ACT1023: Metal Finishing & Body Filling	3	2
	ACT1044: Refinishing I	2	1
	ACT2043: Refinishing II	2	1
	ACT2044: Final Detail	2	1
Broadcasting & Electronic Media Fall	RTV1002: Beginning Television	3	2
	RTV1003: Writing for Television and Radio	3	2
	RTV1010: Fundamentals of Podcasting	3	2
Broadcasting & Electronic Media Spring	RTV1000: Introduction to Electronic Media	3	2
	RTV1001: Radio Programming & Production I	3	2
	RTV1011: Gaming, Vlogging, and Lifestyle Video Live Streaming	3	2
Criminal Justice I Fall	CRJ1010: Introduction to Criminal Justice: SS3	3	2
	CRJ1025: Policing Systems	3	2

	CRJ2009: Criminal Investigation I	3	2
	CRJ2005: Principles of Criminal Law	3	2
	CRJ1027: Crime Scene Investigation	3	2
Criminal Justice I Spring	CRJ1035: Judicial Function	3	2
	CRJ2031: Introduction to Forensic Science & Criminalistics	3	2
<hr/>			
	CRJ 2020: Human Relations & Social Conflict	3	2
Criminal Justice II Fall	CRJ2035: Delinquent Behavior	3	2
	CRJ1045: Correctional Process	3	2
	CRJ2030: Criminology	3	2
	COM2250: Organizational Communication	3	2
Criminal Justice II Spring	LEA1018: Police Report Writing	3	2
	CRJ2057: Victimology	3	2
	CRJ2068: Criminal Profiling	3	2
<hr/>			
	CUA1000: Culinary Program Fundamentals	3	2
Culinary Arts I Fall	CUA1001: Food Safety & Sanitation	2	1
	CUA1045: Introduction to Baking	4	2
	CUA1005: Food Service Concepts & Management Skills	3	2
Culinary Arts I Spring	CUA1025: Introduction to Foods	4	2
	CUA1056: Nutrition for the Hospitality Professional	3	2
<hr/>			
	CUA1027: Soups, Sauces, & Consommés	3	2
Culinary Arts II Fall	CUA1054: Introduction to the Business of Catering	3	2
	BUS1015: Introduction to Business	3	2
	CUA1029: Center of the Plate	4	2
Culinary Arts II Spring	CUA1038: Food & Beverage Service	2	1
	CUA2062: Purchasing for the Hospitality Industry	3	2
<hr/>			
	CNG1020: A+ Certification Preparation	4	2
Cyber Security I Fall	CNG1031: Principals of Information Assurance	3	2
	CIS2023: Linux	3	2
	CNG1024: Networking I: Network +	3	2
Cyber Security I Spring	CNG1032: Network Security Fundamentals	3	2
	CNG1042: Introduction to Cloud Computing Concepts	3	2
<hr/>			
Cyber Security II Fall	CNG2042: Cloud Computing	3	2

	CNG2057: Network Defense and Counter Measures	3	2
	DAT1001: Introduction to Data Science	3	2
	CNG2012: Configuring Windows Server	4	2
Cyber Security II Spring	CNG2059: Enterprise Security	4	2
	CNG2056: Vulnerability Assessment Level 1	3	2
<hr/>			
	DPM1000: Introduction to Diesel Mechanics	2	1
Diesel Power Technology I Fall	DPM1001: Diesel Shop Orientation	2	1
	DPM2006: Heavy Duty Brakes I	3	2
	DPM1020: Basic Heavy-Duty Electricity	2	1
Diesel Power Technology I Spring	DPM1026: Heavy Duty Starting & Charging	3	2
	DPM2007: Hydraulic Systems II	3	2
<hr/>			
	DPM1021: Hydraulic Systems I	3	2
Diesel Power Technology II Fall	DPM1022: Hydraulic Systems II	3	2
	DPM1005: Heavy Duty Powertrains I	3	2
Diesel Power Technology II Spring	DPM1003: Diesel Engines I	4	2
	DPM2003: Diesel Engines II	4	2
<hr/>			
	ECE1011: Introduction to Early Childhood Education	3	2
	HPR1011: CPR for Professionals		
Early Childhood Education Fall	HWE1005: AHA Heartsaver First Aid CPR/AED	0.5	1
	ECE 1031: Guidance Strategies for Young Children	3	2
	ECE2051: Nutrition, Health, & Safety	3	2
	COM2250: Organizational Communication	3	2
	ECE2641: Creativity and the Young Child	3	2
Early Childhood Education Spring	ECE1111: Infant and Toddler Theory and Practice	3	2
	ECE1045: Introduction to Early Childhood Techniques	3	2
<hr/>			
	FST1002: Principles/Emergency Services	3	2
	FST1003: Fire Behavior & Combustion	3	2
Fire Science Technology Fall	FST1006: Fire Prevention	3	2
	FST1009: Occupational Safety & Health for Fire	3	2
Fire Science Technology Spring	FST1005: Building Construction for Fire Protection	3	2
	FST2001: Instructional Methodology	3	2

	FST2002: Strategy & Tactics	3	2
	FST2059: Wildland Firefighting Strategy & Tactics	3	2
	HPR1011: CPR for Professionals	0.5	1
	HPR1039: Medical Terminology	2	1
Medical Office Pathways Fall	MOT1025: Basic Medical Sciences I	3	2
	MOT1026: Basic Medical Sciences II	3	2
	HPR1006: Customer Service in Healthcare	2	1
	HPR1008: Law and Ethics for Health Professionals	2	1
Medical Office Pathways Spring	HPR1045: Medical Record Terminology	2	1
	COM1260: Communication in Healthcare	3	2
	MOT1027: Basic Medical Sciences III	3	2
	MGD1009: Design & Color	3	2
Multimedia Graphic Design I Fall	MGD1012: Adobe Illustrator I	3	2
	MGD1034: Drawing for Illustrators	3	2
	MGD1002: Introduction to Multimedia	3	2
Multimedia Graphic Design I Spring	MGD1011: Adobe Photoshop I	3	2
	MGD1037: Illustration I	3	2
	MGD1020: Production Design	3	2
Multimedia Graphic Design II Fall	MGD1013: Adobe InDesign	3	2
	MGD1014: Typography	3	2
	MGD2011: Adobe Photoshop II	3	2
Multimedia Graphic Design II Spring	PHO1020: Fundamentals of Photography	3	2
	MGD2021: Computer Graphics I	3	2
	VET1002: Veterinary Medical Terminology	1	1
	VET1003: Veterinary Assistant Restraint & Handling	2	1
Veterinary Assistant Fall	VET1004: Assistant Large Animal Nursing	1	1
	VET1009: Applied Companion Animal Behavior	3	2
	VET1020: Office Procedures and Relations	2	1
	VET1014: Vet Assistant Lab & Clinical Procedures	3	2
Veterinary Assistant Spring	VET1017: Veterinary Assistant Surgery & Nursing Care	2	1
	VET1083: Internship	3	2

Welding I Fall	WEL1000: Safety for Welders	1	1
	WEL1006: Blueprint Reading for Welders & Fitters (CC)	4	2
	WEL1025: Intro to Gas Metal Arc Welding (TL, CC)	4	2
Welding I Spring	WEL2050: Layout & Fabrication (CC)	4	2
	WEL1024: Intro to Gas Tungsten Arc Welding (TL, CC)	4	2

Welding II Fall	WEL2024: Advanced Gas Tungsten Arc Welding II	4	2
	WEL2025: Advanced Gas Metal Arc Welding	4	2
Welding II Spring	WEL1013: Oxyfuel & Plasma Cutting	2	1
	WEL1021: Structural Welding I	3	2
	WEL1022: Structural Welding II	3	2

Zookeeping I Fall	ZOO1010: Introduction to Captive Animal Management	2	1
	ZOO1110: Advanced Exhibitory Techniques	3	2
	ZOO1320: Veterinary Zookeeping	3	2
Zookeeping I Spring	ZOO1410: Invertebrate Zoology	4	2
	ZOO2410: Aquatic & Terrestrial Invertebrate Husbandry	4	2

Zookeeping II Fall	ZOO1510: Fish Husbandry & Aquaria Management	4	2
	ZOO1210: Exhibit & Horticulture Design for Zoo Exhibits	4	2
Zookeeping II Spring	ZOO1610: Herpetology	4	2
	ZOO2610: Reptile & Amphibian Husbandry	4	2

CNA PPSC Course	Credit Hours at PPSC	High School Credit in D20
HPR1011: CPR for Professionals	0.5	1 unweighted core elective
NUA1001: Nurse Aide Health Care Skills	4	2 unweighted core electives
NUA1070: Nurse Aid Clinical Experience	1	1 unweighted core elective
NUA1071: Clinical: Advanced Nurse Aid	1	1 unweighted core elective

EMT PPSC Course	Credit Hours at PPSC	High School Credit in D20
EMS1021: EMT Fundamentals	3	2 unweighted core electives
EMS1022: EMT Medical Emergencies	4	2 unweighted core electives
EMS1023: EMT Trauma Emergencies	2	1 unweighted core elective

EMS1024: EMT Special Considerations	2	1 unweighted core elective
HPR1011: CPR for Professionals	0.5	1 unweighted core elective
EMS1070: EMT Clinical	1	1 unweighted core elective

---

## Appendix B

### Pikes Peak State College Courses that are Guaranteed to Transfer and Approved for Weighted Credit

Course Prefix	Course ID	Title	College Credits	Weighted High School Credits	Type of HS Credit
ANT	1001	Cultural Anthropology	3	2	Social Science
ART	1110	Art Appreciation	3	2	Arts
ART	1112	Art History Renaissance to 1900	3	2	Arts
ASL	2221	American Sign Language IV	3	2	World Language
ASL	2222	American Sign Language V	3	2	World Language
AST	1110	Planetary Astronomy I, with Lab	4	2	Lab Science
AST	1120	Stellar Astronomy II, with Lab	4	2	Lab Science
BIO	1003	Principles of Animal Biology	3	2	Science
BIO	1004	Biology: A Human Approach	4	2	Science
BIO	1005	Science of Biology, with Lab	4	2	Lab Science
BIO	1111	General College Biology I, with Lab	5	2	Lab Science
BIO	1112	General College Biology II, with Lab	5	2	Lab Science
BIO	2101	Anatomy & Physiology I, with Lab	4	2	Lab Science
BIO	2102	Anatomy & Physiology II, with Lab	4	2	Lab Science
CHE	1005	Chemistry in Context, with Lab	5	2	Lab Science
CHE	1011	Introduction to Chemistry I, with Lab	5	2	Lab Science
CHE	1012	Introduction to Chemistry II, with Lab	5	2	Lab Science
CHE	1111	General College Chemistry I, with Lab	5	2	Lab Science
CHE	1112	General College Chemistry II, with Lab	5	2	Lab Science
COM	1250	Interpersonal Communication	3	2	Core Elective
CRJ	1010	Introduction to Criminal Justice	3	2	Core Elective
ECO	2001	Principles of Macroeconomics	3	2	Social Science
ECO	2002	Principles of Microeconomics	3	2	Social Science
ECO	2045	Environmental Economics	3	2	Social Science
ENG	1021	English Composition I	3	2	English
ENG	1022	English Composition II	3	2	English
ENG	1031	Technical Writing I	3	2	English
ENG	2021	Creative Writing I	3	2	English
ENV	1111	Introduction to Environmental Science, with Lab	4	2	Core Elective
GEO	1005	World Regional Geography	3	2	Social Science
GEY	1111	Physical Geology, with Lab	4	2	Lab Science

<b>HIS</b>	1120	The World: 1500 - Present	3	2	World History
<b>HIS</b>	1220	U.S. History Since the Civil War	3	2	US History
<b>HIS</b>	2015	20th Century World History	3	2	World History
<b>HUM</b>	1015	World Mythology	3	2	Core Elective
<b>JOU</b>	1005	Introduction to Mass Media	3	2	Core Elective
<b>LIT</b>	1015	Introduction to Literature	3	2	English
<b>LIT</b>	2055	Children's Literature	3	2	English
<b>MAT</b>	1240	Mathematics for Liberal Arts	4	2	Math
<b>MAT</b>	1260	Introduction to Statistics	3	2	Math
<b>MAT</b>	1340	College Algebra	4	2	Math
<b>MAT</b>	1420	College Trigonometry	3	2	Math
<b>MAT</b>	1440	Pre-Calculus	5	2	Math
<b>MAT</b>	2410	Calculus I	5	2	Math
<b>MAT</b>	2420	Calculus II	5	2	Math
<b>MAT</b>	2430	Calculus III	4	2	Math
<b>MAT</b>	2520	Discrete Mathematics	4	2	Math
<b>MAT</b>	2560	Differential Equations	3	2	Math
<b>MAT</b>	2562	Linear Algebra	4	2	Math
<b>MUS</b>	1020	Music Appreciation	3	2	Arts
<b>PHI</b>	1011	Introduction to Philosophy	3	2	Core Elective
<b>PHI</b>	1012	Ethics	3	2	Core Elective
<b>PHY</b>	1105	Conceptual Physics with Lab	4	2	Lab Science
<b>PHY</b>	1111	Physics: Algebra-based I, with Lab	5	2	Lab Science
<b>PHY</b>	1112	Physics: Algebra-based II, with Lab	5	2	Lab Science
<b>PHY</b>	2111	Physics: Calculus-based I, with Lab	5	2	Lab Science
<b>PHY</b>	2112	Physics: Calculus-based II, with Lab	5	2	Lab Science
<b>PSC</b>	1011	American Government	3	2	Civics
<b>PSC</b>	2020	Introduction to Political Science	3	2	Social Science
<b>PSY</b>	1001	General Psychology I	3	2	Social Science
<b>PSY</b>	1002	General Psychology II	3	2	Social Science
<b>PSY</b>	2221	Social Psychology	3	2	Social Science
<b>PSY</b>	2440	Human Growth & Development	3	2	Social Science
<b>PSY</b>	2441	Child Development	3	2	Social Science
<b>PSY</b>	2552	Abnormal Psychology	3	2	Social Science
<b>SOC</b>	1001	Introduction to Sociology I	3	2	Social Science
<b>THE</b>	1005	Theatre Appreciation	3	2	Core Elective

## Appendix C

### University of Colorado Colorado Springs Courses that are Guaranteed to Transfer and Approved for Weighted Credit

Course Prefix	Course ID	Title	College Credits	Weighted High School Credits	Type of HS Credit
ANTH	1040	Introduction to Cultural Anthropology	3	2	Social Science
BIOL	1000	Biology in the Modern World	3	2	Science
BIOL	1060	Introductory Biology Laboratory	1	1	Lab Science
BIOL	1300	General Biology: Organismic Biology	3	2	Science
CHEM	1101	Chemistry in the Modern World	3	2	Science
CHEM	1102	Chemistry in the Modern World Laboratory	1	1	Lab Science
CHEM	1111	Environmental Science	3	2	Science
CHEM	1112	Environmental Science Laboratory	1	1	Lab Science
CHEM	1201	Introduction to Chemistry	4	2	Science
CHEM	1401	General Chemistry I	4	2	Science
CHEM	1402	General Chemistry Laboratory I	1	1	Lab Science
ECON	1050	Economics in Practice	3	2	Social Science
ENGL	1310	Rhetoric and Writing I	3	2	English
ENGL	1410	Rhetoric and Writing II: Argument and Research	3	2	English
ENGL	1500	Introduction to Literature for Non-Majors	3	2	English
FILM	1000	Introduction to Film Studies	3	2	Core Elective
GES	1990	Introduction to Human Geography	4	2	Social Science
HIST	1530	Emergence of Modern America, 1865-1920	3	2	US History (Must be taken in addition to HIST1540)
HIST	1540	U.S.: Recent America, 1918-Present	3	2	US History (Must be taken in addition to HIST1530)
MATH	1040	College Algebra	3	2	Math
MATH	1050	Elementary Functions of Calculus	4	2	Math

<b>PES</b>	1000	Physics in Everyday Life	3	2	Science
<b>PES</b>	1010	Physics for Life Science I— Algebra Based	4	2	Science
<b>PES</b>	1050	General Astronomy I	3	2	Science
<b>PES</b>	1090	General Astronomy Laboratory I	1	1	Lab Science
<b>PHIL</b>	1000	Introduction to Philosophy	3	2	Core Elective
<b>PHIL</b>	1020	Introduction to Ethics	3	2	Core Elective
<b>PHIL</b>	1120	Critical Thinking	3	2	Core Elective
<b>PSC</b>	1100	The American Political System	3	2	Civics
<b>SOC</b>	1110	Introduction to Sociology	4	2	Social Science
<b>WEST</b>	1010	Introduction to Social Justice Studies	3	2	Core Elective

## Appendix D

### Courses Currently Authorized for PLTW or CU Succeed Credit at D20 High Schools

Program	High School	Teacher First Name	Teacher Last Name	Subject	Catalog	Class Name	Credits	Meets HLC Criteria after Sept 1, 2025
CU	Air Academy High School	Linda	Aragon	ASL	1010	American Sign Language I	4	Yes
CU	Air Academy High School	Lindsay	Bornhofen	BUAD	1000	Intro to Business	3	Yes
CU	Air Academy High School	Jason	Catron	MATH	1050	Elementary Functions of Calculus (Pre Calculus)	4	No
CU	Air Academy High School	Amy	Cofield	MATH	1050	Elementary Functions of Calculus (Pre Calculus)	4	No
CU	Air Academy High School	Jennifer	Gunderson	ASL	1010	American Sign Language I	4	Yes
CU	Air Academy High School	Jennifer	Gunderson	ASL	2110	American Sign Language III	4	Yes
PLTW	Air Academy High School	Adam	Truex	ENGR	1411	Digital Electronics	2	Covered by College of Engineering agreement
PLTW	Air Academy High School	Adam	Truex	ENGR	1502	Principles of Engineering	3	Covered by College of Engineering agreement
PLTW	Air Academy High School	Adam	Truex	ENGR	1503	Introduction to Engineering Design	2	Covered by College of Engineering agreement
PLTW	Air Academy High School	Adam	Truex	ENGR	1506	Civil Engineering & Architecture	3	Covered by College of Engineering agreement
PLTW	Air Academy High School	Adam	Truex	ENGR	1507	Computer Integrated Manufacturing	3	Covered by College of Engineering agreement
PLTW	Air Academy High School	Adam	Truex	ENGR	1509	Computer Science Principals	3	Covered by College of Engineering agreement
CU	Air Academy High School	Linda	Aragon	ASL	2110	American Sign Language III	4	Yes
CU	Air Academy High School	Amy	Cofield	MATH	1350	Calculus I (BC)	4	No

<b>CU</b>	Air Academy High School	Amy	Cofield	MATH	1350	Calculus I (AB)	4	No
<b>CU</b>	Air Academy High School	Amy	Cofield	MATH	1360	Calculus II (BC)	4	No
<b>CU</b>	Air Academy High School	Amy	Cofield	MATH	1050	Elementary Functions of Calculus (Pre Calculus)	4	No
<b>CU</b>	Air Academy High School	Natalie	Thomas (Paluso)	ASL	1010	American Sign Language I	4	Yes
<b>CU</b>	Air Academy High School	Natalie	Thomas (Paluso)	ASL	1020	American Sign Language II	4	Yes
<b>CU</b>	Air Academy High School	Natalie	Thomas (Paluso)	ASL	2120	American Sign Language IV	4	Yes
<b>PLTW</b>	Discovery Canyon Campus High School	Jonathan	Bluff	ENGR	1411	Digital Electronics	2	Covered by College of Engineering agreement
<b>PLTW</b>	Discovery Canyon Campus High School	Jonathan	Bluff	ENGR	1503	Introduction to Engineering Design	2	Covered by College of Engineering agreement
<b>PLTW</b>	Discovery Canyon Campus High School	Jonathan	Bluff	ENGR	1504	Aerospace Engineering	3	Covered by College of Engineering agreement
<b>PLTW</b>	Discovery Canyon Campus High School	Mitchell	Burke	BIOL	1011	Principles of Biomedical Science	3	Covered by Biology Dept agreement
<b>PLTW</b>	Discovery Canyon Campus High School	Mitchell	Burke	BIOL	1012	Human Body Systems	3	Covered by Biology Dept agreement
<b>PLTW</b>	Discovery Canyon Campus High School	Mitchell	Burke	BIOL	1013	Medical Interventions	3	Covered by Biology Dept agreement
<b>PLTW</b>	Discovery Canyon Campus High School	Mitchell	Burke	BIOL	2040	Biomedical Innovation	3	Covered by Biology Dept agreement
<b>CU</b>	Discovery Canyon Campus High School	Amy	Keating	LEAD	1000	American Foundations of Education	3	Yes
<b>PLTW</b>	Discovery Canyon Campus High School	Josh	Kinney	ENGR	1502	Principles of Engineering	3	Covered by College of Engineering agreement
<b>PLTW</b>	Discovery Canyon	Josh	Kinney	ENGR	1503	Introduction to Engineering Design	2	Covered by College of

	Campus High School								Engineering agreement
<b>PLTW</b>	Discovery Canyon Campus High School	Josh	Kinney	ENGR	1506	Civil Engineering & Architecture	3		Covered by College of Engineering agreement
<b>PLTW</b>	Discovery Canyon Campus High School	Josh	Kinney	ENGR	1508	Engineering Design & Development	3		Covered by College of Engineering agreement
<b>CU</b>	Discovery Canyon Campus High School	Katie	O'Hare (Uebelhoer)	MATH	1050	Elementary Functions of Calculus (Pre Calculus)	4		No
<b>CU</b>	Discovery Canyon Campus High School	Katie	O'Hare (Uebelhoer)	MATH	2810	Intro to Basic Statistics	3		No
<b>CU</b>	Discovery Canyon Campus High School	Kathryn (Katy)	Snider	EDUC	2000	Intro to Educational Psychology	3		Yes
<b>CU</b>	Discovery Canyon Campus High School	Kathryn (Katy)	Snider	LEAD	1000	American Foundations of Education	3		Yes
<b>CU</b>	Discovery Canyon Campus High School	Kathryn (Katy)	Snider	PES	1000	Physics in Everyday Life	3		No
<b>CU</b>	Discovery Canyon Campus High School	Janelle	Watkins (Adams)	MATH	1050	Elementary Functions of Calculus (Pre Calculus)	4		No
<b>CU</b>	Pine Creek High School	Tyler (TY)	Allen	HIST	1530	US: Emergence of Modern America, 1865-1920	3		Yes
<b>CU</b>	Pine Creek High School	Tyler (TY)	Allen	HIST	1540	Recent America:1918-Present	3		Yes
<b>CU</b>	Pine Creek High School	Tyler (Ty)	Allen	PSC	1100	The American Political System	3		Yes
<b>CU</b>	Pine Creek High School	Chelsea	Corbitt	MATH	1050	Elementary Functions of Calculus (Pre Calculus)	4		Yes
<b>CU</b>	Pine Creek High School	Tiffanie	Davis	VA	1030	Digital Foundations	3		Yes
<b>CU</b>	Pine Creek High School	Tiffanie	Davis	VA	2150	Beginning Digital Photography	3		Yes
<b>CU</b>	Pine Creek High School	Lindsay	Edy	COMM	2010	Oral Communication in the Workplace	3		Yes
<b>CU</b>	Pine Creek High School	Rudilee	Gabel	MATH	1050	Elementary Functions of	4		Yes

<b>PLTW</b>	Pine Creek High School	Rebecca	Keith	BIOL	1011	Calculus (Pre Calculus) Principles of Biomedical Science	3	Covered by Biology Dept agreement
<b>PLTW</b>	Pine Creek High School	Rebecca	Keith	BIOL	1012	Human Body Systems	3	Covered by Biology Dept agreement
<b>PLTW</b>	Pine Creek High School	Rebecca	Keith	BIOL	1013	Medical Interventions	3	Covered by Biology Dept agreement
<b>PLTW</b>	Pine Creek High School	Rebecca	Keith	BIOL	2040	Biomedical Innovations	3	Covered by Biology Department Agreement
<b>CU</b>	Pine Creek High School	Lisa	McCone	PSY	1000	General Psychology	3	No
<b>CU</b>	Pine Creek High School	Irini	Rinn	ENGL	1310	Rhetoric and Writing 1	3	Yes
<b>CU</b>	Pine Creek High School	Irini	Rinn	ENGL	1410	Rhetoric and Writing II: Argument and Research	3	Yes
<b>CU</b>	Pine Creek High School	Justin	Morrill	ENGL	1500	Introduction to Literature for Non-Majors	3	Yes
<b>CU</b>	Pine Creek High School	Justin	Morrill	ENGL	1700	Special Topics in Literary Explorations	3	Yes
<b>CU</b>	Pine Creek High School	Kristiann	Saunders	MATH	1050	Elementary Functions of Calculus (Pre Calculus)	4	Yes
<b>CU</b>	Pine Creek High School	Jeremy	Saunders	MATH	1050	Elementary Functions of Calculus (Pre Calculus)	4	Yes
<b>CU</b>	Pine Creek High School	April	Pierce	MATH	2350	Calculus III	4	Yes
<b>CU</b>	Rampart High School	Greg	Andersen	MATH	1050	Elementary Functions of Calculus (Pre Calculus)	4	No, but retired
<b>CU</b>	Rampart High School	Robert (Bobby)	Brown	PSC	1100	The American Political System	3	Yes
<b>CU</b>	Rampart High School	Michelle	Robbins	THTR	1000	Intro to Theater	3	Yes
<b>CU</b>	Rampart High School	Alma	Sicinski	ASL	1010	American Sign Language I	4	Yes
<b>CU</b>	Rampart High School	Alma	Sicinski	ASL	1020	American Sign Language II	4	Yes

CU	Rampart High School	Alma	Sicinski	ASL	2110	American Sign Language III	4	Yes
CU	Rampart High School	Alma	Sicinski	ASL	2120	American Sign Language IV	4	Yes
CU	Village High School	Thaddeus	Young	ASL	1010	American Sign Language I	4	Yes
CU	Village High School	Thaddeus	Young	ASL	1020	American Sign Language II	4	Yes
CU	Village High School	Thaddeus	Young	ASL	2110	American Sign Language III	4	Yes
CU	Village High School	Thaddeus	Young	ASL	2120	American Sign Language IV	4	Yes
CU	Village High School	Jason	Catron	MATH	1050	Elementary Functions of Calculus (Pre Calculus)	4	Yes
CU	Village High School	Karlie	Goretski	MATH	1050	Elementary Functions of Calculus (PreCalculus)	4	Yes
CU	Village High School	Laurie	Hughes	BUAD	1000	Introduction to Business	3	Yes
CU	Village High School	Jill	Irwin	ASL	2110	American Sign Language III	4	Yes
CU	Village High School	Jill	Irwin	ASL	2120	American Sign Language IV	4	Yes
CU	Village High School	Katie	Redinger	EDUC	2000	Intro to Educational Psychology	3	Yes
CU	Village High School	Katie	Redinger	LEAD	1000	American Foundations of Education	3	Yes
CU	Village High School	Jason	Smits	MATH	2810	Intro to Basic Statistics	3	No
CU	Village High School	Thaddeus	Young	ASL	1010	American Sign Language I	4	Yes
CU	Village High School	Thaddeus	Young	ASL	1020	American Sign Language II	4	Yes
CU	Village High School	Thaddeus	Young	ASL	2120	American Sign Language III	4	Yes



## Appendix E

### Metropolitan State University of Denver Courses that are Guaranteed to Transfer and Approved for Weighted Outside Agency Credit

Course Prefix	Course ID	Title	College Credits	Weighted High School Credits	Type of HS Credit (Where two options exist, the awarded credit will be based on the prefix transcribed at the university)
ANT	1010	Introduction to Biological Anthropology	3	2	Lab Science
ANT/HON	1310/1311	Introduction to Cultural Anthropology	3	2	Social Science
AST	1040	Introduction to Astronomy--Solar System	4	2	Science
AST	1050	Introduction to Astronomy--Stars and Galaxies	4	2	Science
CET/MET/EET	1040	Introduction to Engineering	3	2	Science
CHE	1100/1150	Principles of Chemistry/Principles of Chemistry Lab	4	2	Lab Science
CHE	1800/1801	General Chemistry I/General Chemistry I Lab	4	2	Lab Science
CHE	1810/1811	General Chemistry II/General Chemistry II Lab	4	2	Lab Science
ECO/HON	2010	Principles of Macroeconomics	3	2	Social Science
ECO/HON	2020	Principles of Microeconomics	3	2	Social Science
ENG	2460	Introduction to Children's Literature	3	2	English
ENV	1200	Introduction to Environmental Science	3	2	Science
GEG	1000	World Regional Geography	3	2	Social Science
GEG	1100	Introduction to Physical Geography	3	2	Social Science

<b>GEG</b>	1300	Introduction to Human Geography	3	2	Social Science
<b>GEL</b>	1010	Physical Geology	4	2	Science
<b>MTH</b>	1080	Mathematics for Liberal Arts	3	2	Math
<b>MTH</b>	1081	Mathematics for Liberal Arts w/Laboratory	3	2	Math
<b>MTH</b>	1110	College Algebra for Calculus	4	2	Math
<b>MTH</b>	1111	College Algebra for Calculus w/Laboratory	4	2	Math
<b>MTH</b>	1120	College Trigonometry	4	2	Math
<b>MTH</b>	1210	Introduction to Statistics	4	2	Math
<b>MTH</b>	1400	Precalculus Mathematics	4	2	Math
<b>MTH</b>	1410	Calculus I	4	2	Math
<b>MTH</b>	1610	Integrated Mathematics I	3	2	Math
<b>MTR</b>	1400	Weather and Climate	3	2	Science
<b>MUS/HON</b>	1000	Introduction to Music	3	2	Arts
<b>PHY</b>	1250	Physics of Aviation	6	2	Science
<b>PHY</b>	2010/2030	College Physics I/College Physics I Laboratory	4	2	Lab Science
<b>PHY</b>	2020/2040	College Physics II/College Physics II Laboratory	4	2	Lab Science
<b>PHY</b>	2311/2321	General Physics I/General Physics I Laboratory	4	2	Lab Science
<b>PHY</b>	2331/2341	General Physics II/General Physics II Laboratory	4	2	Lab Science
<b>PSY</b>	1001	Introductory Psychology	3	2	Social Science
<b>SWK</b>	1010	Introduction to Social Work	3	2	Social Science



